



THE LGC-690 SERIES

Operating and Service Manual

Series includes all variants of LGC-690

Issue A
March 2016



TABLE OF CONTENTS

1. Description	3
2. Installation	3
3. Operation	4
4. Special Conditions for Safe Use	4
5. Hazardous Location Usage	4
6. Servicing and Maintenance.....	5
6.1. Servicing the LGC-690	5
6.1.1. Accessing the Main Valve Assembly	5
6.1.2. Accessing the Sensor Assembly	7
6.1.3. Figure 1 – Sectional View of the LGC-690.....	8
7. Technical Data.....	9
8. Warranty Statement	9

1. Description

The LGC-690 is a single stage piston sensed pressure regulator, capable of a maximum 414bar inlet pressure, specially designed for control of low outlet pressures typically used on logic control systems where control of stepping has to be within +/-1 bar accuracy.

Features include balanced main valve, large piston sensing element and lower entry access to unique seating cartridge assembly with built in filter.

Pressure Equipment Directive (PED) 2014/68/EC Declaration

This equipment is designed and manufactured in accordance with Sound Engineering Practice (SEP) Article 4, Paragraph 3 of the directive 2014/68/EC. As such, CE marking must not be applied. The equipment is marked under section 3.3 of Essential Safety Requirements of the directive.

2. Installation

Before system start-up, it is recommended that all systems be pressure tested, leak tested and purged with an inert gas such as nitrogen.

Prior to placing into service ensure that the regulator is in the fully closed position, with the adjusting mechanism turned completely anti-clockwise.

Check the model number reference to ensure that the pressure range complies with the installation requirements.

Visually inspect the regulator for any signs of damage or contamination. If any foreign materials are present and cannot be removed from the regulator, or if the threads on the regulator appear to be damaged, please contact the office immediately to arrange for the regulator to be returned for service.

The Inlet and Outlet ports are clearly marked. Select the correct size and type of connection fittings for these ports which are indicated in the regulators part number. National Pipe Thread (NPT) 'N' options are available on this regulator. For NPT threads, ensure that PTFE tape is applied correctly to the fittings, applying two overlapping layers in the direction of the thread, taking care that the tape does not come into contact with the first thread.

Any gauge ports on the regulator will be 1/4" NPT unless otherwise stated. If any gauge port is not required, ensure that the port is plugged prior to installation.

The media supplied to the regulator must be clean. Contamination can damage the seat which may cause the regulator to fail. Filtration suited to the application is recommended upstream of the regulator.

Should further assistance or information be required in relation to installation of any Pressure Tech regulator please contact the office, giving reference to the regulators part number and/or serial number.

3. Operation

Turning the hand wheel clockwise compresses the load spring, which in turn opens the main valve, and allows the inlet pressure to pass through the orifice until the outlet pressure is equivalent to the loading forces set by the compressed spring.

The LGC-690 incorporates a segregated captured vent, which allows the outlet pressure to be reduced whilst turning the hand wheel anti-clockwise. Excess pressure is vented off through the 'Vent' port marked at the bottom of the regulator. This port should not be plugged or blocked at any time.

The LGC-690 series may be offered with pressure limiting, pressure locking or pre-set pressure options:

Pressure limited regulators are fitted with locknuts on the adjusting mechanism in order to limit the maximum allowable downstream pressure. Regulators fitted with pressure limiting locknuts will state the limited pressure on the regulator label and this will also be indicated in the part number.

Pressure locking regulators are fitted with a locking cap which may be set (when specified) to pre-determined requirements. It is secured in place by three M5 grub screws which lock against the bonnet of the regulator creating an anti-tamper device to ensure the pressure cannot be adjusted accidentally.

Pre-set pressure regulators are adjusted (factory set) to specified customer requirements within a given pressure range.

Both pressure locking and pre-set pressure regulators will be fully adjustable through a given pressure range and the maximum allowable working pressures will be indicated on the regulator label and in the part number.

*Note - A table is available on request defining allowable tolerances for set points within a given pressure range.

4. Special Conditions for Safe Use

Turning the hand wheel anti-clockwise (with pressure on the outlet) should be refrained on non-venting regulators. Pressure should be reduced in this case by venting downstream of the regulator, and turning the hand wheel simultaneously anti-clockwise.

5. Hazardous Location Usage

This equipment has not been manufactured specifically for use in potentially explosive atmospheres and as such an ignition hazard assessment has not been carried out on this product. If the user should wish to use this product in such an environment where there may be a potentially explosive atmosphere then it is the responsibility of the user to conduct an ignition hazard assessment against 99/92/EC.

6. Servicing and Maintenance

Servicing and maintenance work on the LGC-690 regulators should only be performed after fully reading and understanding the Operating and Servicing Manual. Any uncertainty should be clarified with Pressure Tech before working on the regulator.

Pressure Tech Ltd recommends the use of Krytox GPL 205 during servicing.

Prior to commencing service, please ensure that:

- The equipment has been de-pressurised
- The load spring has been de-compressed by turning the adjusting mechanism fully anti-clockwise
- Applications involving toxic, flammable or corrosive media have been fully purged

To ensure the best possible results from servicing, when re-assembling the regulator and any assemblies within it, ensure that all areas of the components and the regulator body are cleaned and free from contaminants which may result in failure of the regulator.

6.1. Servicing the LGC-690

*Note: fig 1 should be used as a reference for the following set of instructions

6.1.1. Accessing the Main Valve Assembly

The LGC-690 incorporates a unique main valve cartridge design which houses the valve components in one assembly for ease of installation.

To access the Main Valve Assembly (MVA):

- i. Secure the body (32) of the regulator in a vice and using a 25mm open ended spanner or adjustable, loosen and remove the bottom nut (33).
- ii. Secure the assembly upright in a vice against the flats of the bottom nut (33)
- iii. Remove the O-ring (7) from the assembly
- iv. Using a 18mm open ended spanner or adjustable, loosen and remove the filter nut (34)
- v. Lift the PEEK seat (30) from the assembly
- vi. Remove the back-up rings (14) and the filter (2) from the assembly
*Note: The filter should be flushed clean prior to reassembly
- vii. Using a 14mm open ended spanner or adjustable, loosen and remove the cartridge (28) from the bottom nut (33)
- viii. Push the main valve (29) from the cartridge (28) and then remove the valve spring (27)
- ix. Replace the O-ring seals (5, 9, 12, 13, 26) on the bottom nut (33)
- x. With the bottom nut (33) secured in a vice, screw the cartridge (28) in place and tighten using a 14mm open ended spanner or adjustable

- xi. Place the valve spring (27) and main valve (29) into the cartridge
- xii. Position the filter (2) onto the cartridge (28) with a back-up ring (14) on either side
- xiii. Place the PEEK soft seat (30) to rest on the top of the main valve (29)
- xiv. Screw the filter nut (34) onto the cartridge (28), ensuring that the PEEK seat (30) locates correctly into it
 - *Note: screw the filter nut finger tight until it engages the valve components, then apply a quarter turn. There should be some movement under the filter nut which can be felt by pressing onto the PEEK seat. If there is no movement, the filter nut is too tight and should be backed off slightly until there is some movement.
- xv. Locate the O-ring (7) around the tip of the PEEK seat (30)
- xvi. The complete assembly can now be screwed into the regulator body (32)

To ensure that the main valve assembly has been correctly and effectively installed it may be required to perform the appropriate seat leak test as per ANSI/FCI 70-2.

The drawing below illustrates the main valve cartridge assembly:

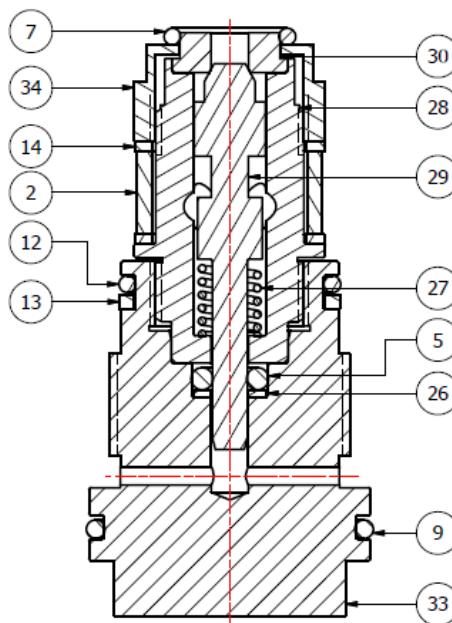

PARTS LIST		
ITEM	PART NUMBER	DESCRIPTION
2	FILT-16.8-20.9.S40	FILTER ELEMENT
5	OR-0036-24	O-RING STD
7	OR-0106-18	O-RING STD
9	OR-0270-20	O-RING STD
12	OR-BS019	O-RING STD
13	ORB-BS019	PTFE BACK UP RING
14	ORB-PT-C-200	PTFE BACK UP RING
26	PT-C-183	BACK UP
27	PT-C-199	COMPRESSION SPRING
28	PT-LGC-690-001	CARTRIDGE
29	PT-LGC-690-004	MAIN VALVE
30	PT-LGC-690-005	SOFT SEAT
33	PT-LGC-690-002	BOTTOM NUT
34	PT-LGC-690-003	FILTER NUT

6.1.2. Accessing the Sensor Assembly

- i. Remove the securing M3 grub screw (4) from the regulator body (32).
- ii. Unscrew the M3 pan screw (3) and remove the name plate (23) from the hand wheel (22).
- iii. Unscrew the locknut (25) using a 24mm socket and remove the hand wheel (22) from the adjusting screw (19).
- iv. With the regulator secured up-right in a vice, remove the bonnet (18) by using a torque wrench or equivalent with 47mm open end.
- v. Un-screw and lift the top works from the assembly, inclusive of the bonnet (18), load spring (37) and adjusting mechanism (1, 19, 20, 21).
- vi. The sensor assembly (15, 17, 35, 36) can be removed from the body by using pliers or mole grips against the flats of the spring rest (17).
- vii. With the sensor assembly removed, it is possible to remove the connector pin (31) and baffle plate (24) from the body. Use needle nosed pliers to carefully grip the connector pin and lift out of the body.
- viii. Visually inspect the connector pin (31) for signs of damage and replace as required.
- ix. Grip the flats of the lower spring rest (17) in a vice so that the vent seat (15) is facing.
- x. The vent seat (15) can be removed from the sensor (36) along with the 5mm x 1mm 'O' ring (6) using a slotted screwdriver.
- xi. Inspect the vent seat (15) for damage and replace as required, being careful not to damage the sealing face during installation.
- xii. To access the sensor O-rings, secure the flats of the spring rest (17) in a vice and using an 18mm open ended spanner or adjustable and the sensor (36) can then be removed from the sensor holder (35).
- xiii. Replace all O-rings (8, 9, 10, 11) located on the sensor (36) and sensor holder (35) prior to reassembly, ensuring adequate lubrication is used.
- xiv. Insert the sensor (36) into the sensor holder (37) and screw the lower spring rest (17) in place.
- xv. Grip the flats of the lower spring rest (17) in a vice and tighten the sensor (36) against it using the flats at the base of the sensor.
- xvi. Position the connector pin (31) into the baffle (24) and grip the top of the connector pin such that the two components may be carefully placed into the bore within the regulator body (32).
- xvii. The sensor assembly (15, 17, 35, 36) may then be placed into the regulator body (32).
- xviii. Place the load spring (37) onto the spring rest (17) and locate the adjusting mechanism (1, 19, 20, 21) onto the load spring and screw the bonnet (18) onto the body (32).
- xix. Torque the bonnet (18) to approximately 90 – 100 Nm and tighten the M3 grub screw (4) to secure.
- xx. Place the hand wheel (22) onto the adjusting screw (19) and screw and tighten the lock nut (25).
- xxi. Secure the nameplate (23) with the M3 pan screw (3).

6.1.3. Figure 1 – Sectional View of the LGC-690

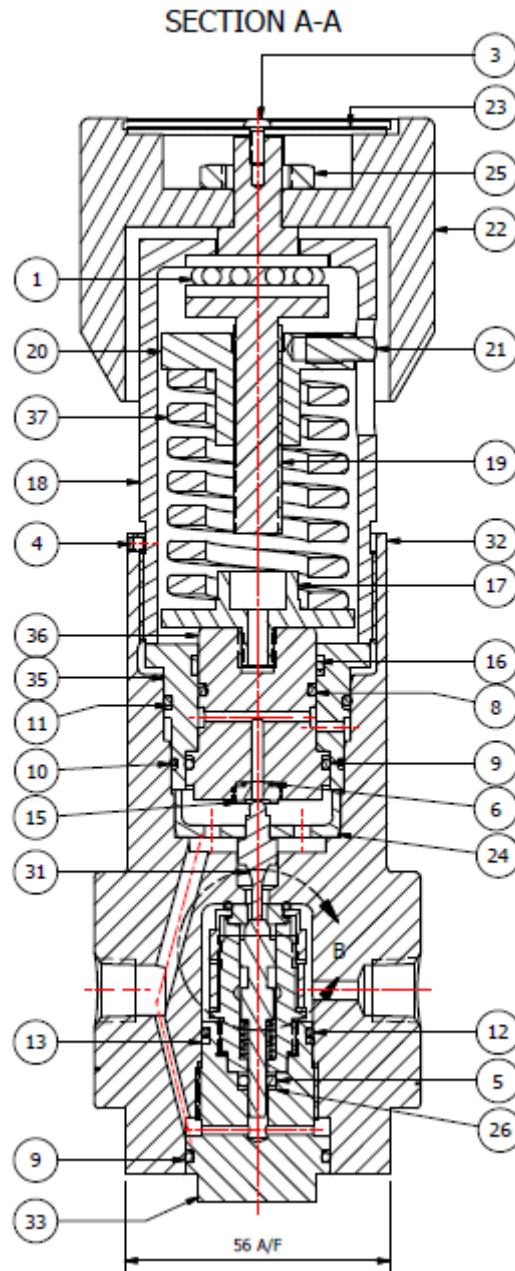
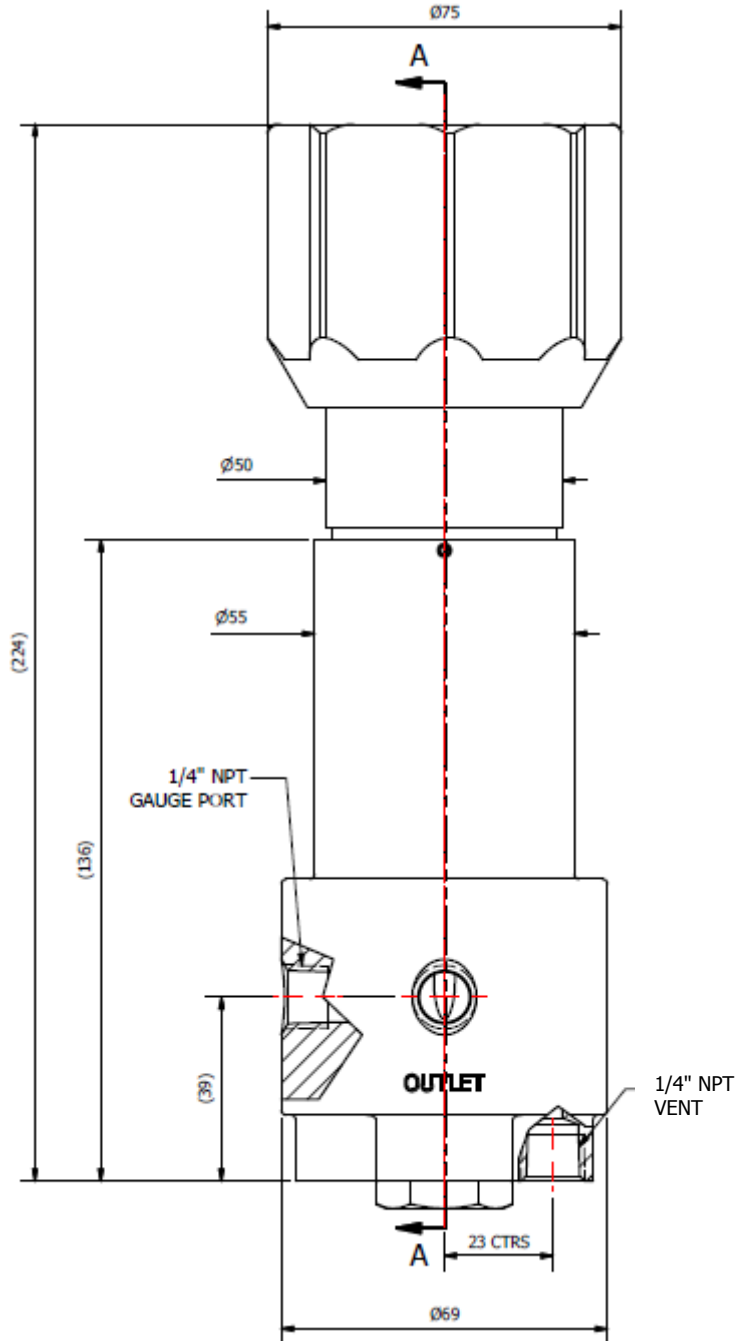

PARTS LIST		
ITEM	PART NUMBER	DESCRIPTION
1	BEAR-51103-SS	BEARING 420 SS
2	FILT-16.8-20.9.S40	FILTER ELEMENT
3	FIT-M3-08-A4-70.0-SKT-BTN	M3 SCREW
4	FIT-M3X3	GRUB SCREW
5	OR-0036-24	O-RING STD
6	OR-0050-10	O-RING STD
7	OR-0106-18	O-RING STD
8	OR-0210-20	O-RING STD
9	OR-0270-20	O-RING STD
10	OR-0340-15	O-RING STD
11	OR-0360-20	O-RING STD
12	OR-BS019	O-RING STD
13	ORB-BS019	PTFE BACK UP RING
14	ORB-PT-C-200	PTFE BACK UP RING
15	PT-690-016-004	PEEK VENT SEAT
16	PT-C-038	SLIDE RING
17	PT-C-039	SPRING REST
18	PT-C-040-002	BONNET
19	PT-C-043-004	ADJUSTING SCREW
20	PT-C-045	ADJUSTING NUT
21	PT-C-046	SLOT SCREW
22	PT-C-048-001	LARGE NYLON HAND WHEEL
23	PT-C-049	NAMEPLATE
24	PT-C-072-001	BAFFLE PLATE
25	PT-C-132	LOCK NUT
26	PT-C-183	BACK UP
27	PT-C-199	COMPRESSION SPRING
28	PT-LGC-690-001	CARTRIDGE
29	PT-LGC-690-004	MAIN VALVE
30	PT-LGC-690-005	SOFT SEAT
31	PT-LGC-690-006	CONNECTOR
32	PT-LGC-690-B-02N-SS	BODY - 'B' PORTING
33	PT-LGC-690-002	BOTTOM NUT
34	PT-LGC-690-003	FILTER NUT
35	PT-LGC-690-007	SENSOR HOLDER
36	PT-LGC-690-008	SENSOR
37	SPR-V40X89	LOAD SPRING

7. Technical Data

Fluid Media:	All liquids compatible with materials of construction	
Max Inlet Pressure:	<u>Body Material</u>	<u>MWP</u>
	S31603/S31600	414 bar
	S32205	690 bar
Outlet Pressure Range:	0-15 bar	
Operating Temperature:	-15°C to +80°C	
Materials:	Body and Trim: S31603/S31600 (standard construction) Seat: PEEK	
Main Valve Assembly:	Balanced 40 Micron Filter Element	
Flow Capacity (Cv):	0.3	
Leakage:	Class V as per ANSI/FCI 70-2	

8. Warranty Statement

Pressure Tech Ltd guarantee all products correspond with their specification at the time of delivery and, with exception to wear and tear, wilful damage, negligence, and abnormal working conditions, will be free from defects for a period of 12 months from date of delivery.