



THE ACS-300 SERIES

Operating and Service Manual

Series includes all variants of ACS-300/310

Issue B
January 2016



TABLE OF CONTENTS

1. Description	3
2. Installation	3
3. Operation	4
3.1. Operating the ACS-300	4
3.2. Operating the second stage LF-300	4
4. Special Conditions for Safe Use	5
5. Hazardous Location Usage	5
6. Servicing and Maintenance.....	5
6.1. Servicing the ACS-300	6
6.1.1. System Strip Down (Recommended).....	6
6.1.2. Accessing the Main Valve Assembly	7
6.1.3. Adjusting the Set Point (2 nd Stage only)	8
6.1.4. System Assembly (Recommended)	9
6.1.5. To Reset the Changeover Mechanism	10
6.1.6. Verifying the Set Point	10
6.1.7. Testing the Changeover System	11
6.1.8. Troubleshooting.....	11
6.1.9. Figure 1 – View of the ACS-300.....	12
6.1.10. Figure 2 – Sectional View of the ACS-300.....	13
7. Technical Data.....	14
8. Warranty Statement	14
Annex A. LF-310 – ‘Solid Disk’ Main Valve Design	15
A.1. Description.....	15
A.2. Servicing.....	15
A.2.1. Figure 2 – Detail A: LF-310 ‘Solid Disk’ MVA (sectional).....	15
A.2.2. Figure 3 – Exploded View of LF-310 ‘Solid Disk’ MVA	15

1. Description

The ACS-300 'Auto Changeover System' consists of two LF-300 single stage diaphragm sensed pressure regulators, which are set to allow a continuous gas supply from two banks of gas cylinders for those critical applications where processes cannot be interrupted, or where essential life support situations demand it. Upon depletion of one bank, the other will automatically cut in. A quick switch of the lever ensures the supply is reset to its original value. The lever may also be used to manually change the supply at any stage. An optional second stage LF-300 series regulator prevents fluctuations in outlet pressure.

The ACS-310 option is also available and utilises the LF-310 solid disk type main valve assembly as covered in Annex A.

Pressure Equipment Directive (PED) 2014/68/EC Declaration

This equipment is designed and manufactured in accordance with Sound Engineering Practice (SEP) Article 4, Paragraph 3 of the directive 2014/68/EC. As such, CE marking must not be applied. The equipment is marked under section 3.3 of Essential Safety Requirements of the directive.

2. Installation

Before system start-up, it is recommended that all systems be pressure tested, leak tested and purged with an inert gas such as nitrogen.

Prior to placing into service ensure that the second stage regulator is in the fully closed position, with the adjusting mechanism turned completely anti-clockwise.

Check the model number reference to ensure that the pressure range complies with the installation requirements.

Visually inspect the regulator for any signs of damage or contamination. If any foreign materials are present and cannot be removed from the regulator, or if the threads on the regulator appear to be damaged, please contact the office immediately to arrange for the regulator to be returned for service.

The Inlet and Outlet ports are clearly marked. Select the correct size and type of connection fittings for these ports which are indicated in the regulators part number. National Pipe Thread (NPT) 'N' are utilised on this regulator. For NPT threads, ensure that PTFE tape is applied correctly to the fittings, applying two overlapping layers in the direction of the thread, taking care that the tape does not come into contact with the first thread. Any gauge ports on the regulator will be 1/4" NPT unless otherwise stated. If any gauge port is not required, ensure that the port is plugged prior to installation.

The media supplied to the regulator must be clean. Contamination can damage the seat which may cause the regulator to fail. Filtration suited to the application is recommended upstream of the regulator.

Should further assistance or information be required in relation to installation of any Pressure Tech regulator please contact the office, giving reference to the regulators part number and/or serial number.

3. Operation

3.1. Operating the ACS-300

The schematic below shows a typical installation example. The position of the handle determines which supply will be used (the 'side in service'). With reference to the image below, the current position of the handle means that changeover regulator A (CRA) connected to Supply A will be 'in service' and changeover regulator B (CRB) connected to Supply B will be on 'standby'. The pressure remaining from each supply can be seen on the reference gauges (optional) attached to the respective regulators. Once the pressure has depleted below the set point from Supply A, the regulator in service is then unable to supply the process and the standby regulator will then automatically cut in and a constant supply is maintained.

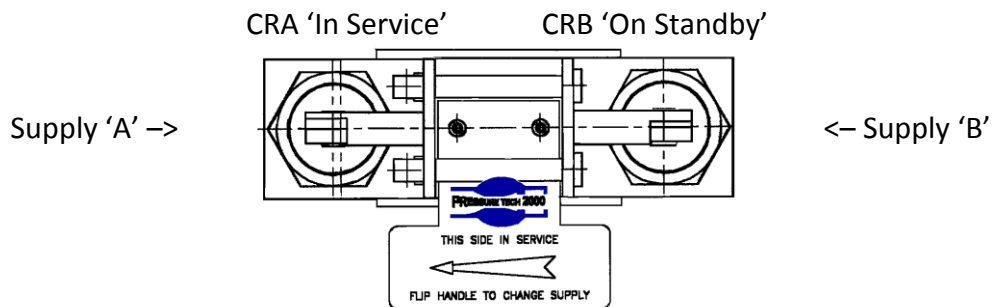

At this stage, the handle on the auto changeover regulator should be flipped and this will reverse the regulator set-up. The standby regulator (CRB) from Supply B now becomes the side in service and the regulator (CRA) from Supply A is now on standby. At this stage, Supply A can be replenished with a new cylinder(s). Once the empty cylinder(s) has been replaced, this process will continually repeat.

*Note: The handle can be flipped at any stage during the process if for any reason the side in service must be changed.

3.2. Operating the second stage LF-300

Turning the adjusting mechanism clockwise compresses the spring, which in turn opens the main valve and allows the inlet pressure to pass through the seat orifice until the outlet pressure is equivalent to the loading forces set by the compressed spring. Increase the outlet pressure in this way until the desired pressure is achieved.

To reduce the outlet pressure, the adjusting mechanism should be turned anti-clockwise whilst the media is flowing, or whilst venting downstream of the regulator. The desired outlet pressure should be set whilst increasing the pressure. Do not exceed the maximum inlet and outlet pressures of the regulator which are indicated on the regulator label.

4. Special Conditions for Safe Use

The ACS-300 series are non-venting type regulators. The outlet pressure from the second stage regulator shall be reduced by venting downstream of the regulator whilst simultaneously turning the adjusting mechanism anti-clockwise.

Check valves and/or isolation valves should be installed between the cylinders and the auto changeover regulators to protect personnel during bottle changes. Toxic and corrosive gases should also include a block and bleed arrangement, which can be supplied by Pressure Tech to individual requirements.

It is recommended that the supply from the cylinders is opened gradually to prevent the regulator components being exposed to shock and avoid damage to any of the process pipe work.

5. Hazardous Location Usage

This equipment has not been manufactured specifically for use in potentially explosive atmospheres and as such an ignition hazard assessment has not been carried out on this product. If the user should wish to use this product in such an environment where there may be a potentially explosive atmosphere then it is the responsibility of the user to conduct an ignition hazard assessment against 99/92/EC.

6. Servicing and Maintenance

Servicing and maintenance work on the ACS-300 regulators should only be performed after fully reading and understanding the Operating and Servicing Manual. Due to the typical nature of the gases the regulator can be used with, the operator should not endanger himself/herself or others by working on this regulator without prior knowledge on the Health and Safety concerns relating to handling of technical gases. Any uncertainty should be clarified with Pressure Tech before working on the regulator.

Pressure Tech Ltd recommends the use of Krytox GPL 205 during servicing.

Prior to commencing service, please ensure that:

- The equipment has been de-pressurised
- The load spring has been de-compressed by turning the adjusting mechanism fully anti-clockwise
- Applications involving toxic, flammable or corrosive media have been fully purged

To ensure the best possible results from servicing, when re-assembling the regulator and any assemblies within it, ensure that all areas of the components and the regulator body are cleaned and free from contaminants which may result in failure of the regulator.

*Note: Ensure that the ACS is disconnected from any process inlet and outlet pipe work prior to servicing.

6.1. Servicing the ACS-300

*Note: For the purpose of the following instructions, the changeover regulators will be referred to as changeover regulator A (CRA) and changeover regulator B (CRB) respectively. The supply pressure gauges will also be referred to as pressure gauge A (PGA) and pressure gauge B (PGB) respectively. Illustration below is in bird's eye view and is for reference purpose only.

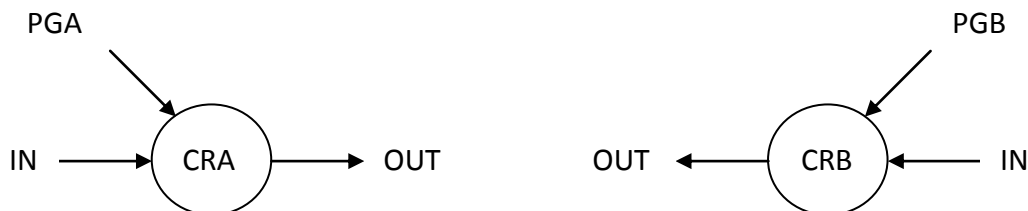

6.1.1. System Strip Down (Recommended)

*Note: Fig 1 should be used as a reference for the following set of instructions

The ACS must be stripped down of all inlet pipe work and connections to allow servicing of the regulators. The following instruction details the recommended disassembly method:

- i. Place the assembly upside down and remove the six M5 screws and washers to separate the changeover system and changeover spacers (43) from the panel (37).
- ii. With the changeover system secured upright in a vice, use a 41mm open ended spanner or adjustable to loosen and remove the two upper panel mount rings (7) located on the top side of the bracket support (1).
- iii. The changeover mechanism (1, 2, 3, 4, 6) can then be lifted from the assembly.
*Note: The remaining two lower panel mount rings should be left in position on the respective regulators and where possible limited in movement during service to maintain the set position of the changeover mechanism. The two upper panel mount rings removed initially can be used to prevent movement by tightening them up to the lower mount rings.
- iv. The left and right process inlet pipe work assemblies (39, 40, 41, 44, 45) can be removed from both CRA and CRB whilst securing the changeover regulator assembly in a vice.
*Note: It is not necessary to disassemble the left and right pipe work assemblies.
- v. Remove the two transfer rods (23) and then CRA and CRB can be removed from the changeover connecting block (5).
*Note: ensure that the two transfer rods (23) are removed as they will fall from the assembly when upside down.
- vi. If required, PGA (27) and PGB (27) can then be removed from the changeover regulators using a 9/16" open ended spanner on the flats of the gauge (*Important*).
- vii. The second stage regulator (SSR) can be removed by disconnecting from the 3" extension (28). Again, if required, the outlet pressure gauge (27) can be removed using a 9/16" open ended spanner on the flats of the gauge (*Important*).

6.1.2. Accessing the Main Valve Assembly

*Note: Fig 2 should be used as a reference for the following set of instructions

Ensure that the changeover regulator adjusting screw (22) or second stage regulator hand wheel (35) is fully wound anti clock wise to release the load on the spring prior to service.

To access the Main Valve Assembly (MVA):

- i. With the flats of the regulator body (8/26/29) secured in a vice, loosen the bonnet (20) using a 47mm wrench.
- ii. Remove the upper spring rest (17), 10mm ball bearing (21), load spring (19/31), diaphragm washer (15), lower spring rest (16) and diaphragm (14) from the assembly.
- iii. The seat nut (10) can then be removed using a 12mm socket.
- iv. Remove the main valve (9, 13) and main valve spring (12) from the assembly.
- v. Visually inspect the seat nut (10) and soft seat (13) for damage under a microscope.
- vi. Replace the main valve spring (12) and main valve (9, 13) and place into the regulator body (8/26/29).
- vii. Replace seat nut (10) fitted with new 5x1mm o-ring (11) taking care not to damage its sealing face against the tip of the valve.
- viii. To ensure positive sealing, it is recommended that a new diaphragm (14) is placed centrally into regulator body (8/26/29) ensuring that the outermost convolutions are facing towards the bonnet (20).
- ix. Replace the 21x1mm o-ring (18) on the lower spring rest (16), insert into the diaphragm washer (15) and place on top of the diaphragm (14).
- x. Place the load spring (19/31), upper spring rest (17) and 10mm ball bearing (21) to the assembly.
- xi. Screw the bonnet (20) onto the assembly and using a torque wrench with a 47mm open ended attachment, tighten to 160Nm.

It is recommended that all parts in the repair kits are used. Any defect parts removed during the service should be disposed of. Parts should be kept clean in line with media requirements. Following re-assembly of the regulator, pressure tests should be made to both the inlet and outlet side of the regulator, to ensure there is no internal or external leakage across the regulator.

To ensure that the main valve assembly has been correctly and effectively installed it may be required to perform the appropriate seat leak test as per ANSI/FCI 70-2.

*Note: After servicing the changeover regulators, ensure that they are each reset to the correct pressure (specified in 7. Technical Data) before following 6.1.4. System Assembly. **IMPORTANT:** Ensure that the changeover regulators are set to the same outlet pressure using the same inlet pressure – for example each changeover regulator is set at 20 bar out with a supply of 210 bar inlet pressure.

6.1.3. Adjusting the Set Point (2nd Stage only)

*Note: Fig 2 should be used as a reference for the following set of instructions

It is not recommended (or necessary) to remove the Hand Wheel during service as this will affect the set point of the regulator. Should it be required to adjust the set point please follow the instructions below:

- i. Remove the nameplate (34) and cap (35) from the hand wheel (33) and loosen the lock nut (32) such that the hand wheel is able to spin freely on the adjusting screw (30)
- ii. Connect the correct fittings to the Inlet and Outlet ports of the regulator. Ensure that any gauge ports are plugged or that the correct gauge is fitted
- iii. With the regulator body (29) secured in a vice apply the Maximum Working Pressure (MWP) to the Inlet of the regulator
- iv. Connect the Outlet port to a calibrated pressure test gauge appropriate to the required set pressure. As the regulator is non-venting, ensure that a ball/needle valve is fitted to allow pressure to be relieved downstream of the regulator
- v. Using a slotted screwdriver, turn the adjusting screw (30) clockwise until the desired set point has been reached
- vi. Ensure repeatability by allowing flow through the regulator using the ball/needle valve
- vii. With the outlet pressure set, screw the first lock nut (32) to the base of the adjusting screw (30) against the bonnet (20)
- viii. Position the hand wheel (33) onto the lock nut (32). Ensure that the lock nut and hand wheel become engaged
- ix. Fasten the second lock nut (32) against the hand wheel (33) and gently begin to tighten using a 13mm socket until it begins to secure itself
- x. At this point, whilst holding the hand wheel (33) continue to tighten whilst simultaneously turning slightly anti-clockwise to prevent it from locking against the bonnet (20)
- xi. Ensure that the lock nut (32) is sufficiently tightened, taking care not to adjust the set point
- xii. Turning of the hand wheel (33) should now also turn the adjusting screw (30) which will control the pressure
- xiii. Turn the hand wheel clockwise until it reaches its set point and check to make sure that the desired outlet pressure is correct.
- xiv. If the set point is not correct, repeat steps v. to xiii.
- xv. Reduce the pressure downstream by venting the pressure through ball/needle valve and then turning the Hand Wheel anti-clockwise until the regulator closes
- xvi. The cap (35) and nameplate (34) can now be placed into the hand wheel (33). Ensure that the information stated on the Nameplate is in accordance with the set pressure of the regulator

6.1.4. System Assembly (Recommended)

*Note: Fig 1 should be used as a reference for the following set of instructions

Perform the following set of reassembly instructions after servicing the regulators in accordance with 6.1.2. Ensure all ports are free of residual PTFE tape and all male threads are cleaned and re-taped prior to assembly.

- i. Secure CRA in a vice and screw the connector block (5) into the outlet port using a 27mm open ended spanner or adjustable.
*Note: Ensure that the final orientation of the two female NPT ports lies horizontally, on the same plane as the regulator ports.
- ii. Then secure CRB in a vice and install the CRA/connector block assembly into the outlet port using a 27mm open ended spanner or adjustable.
- iii. Secure the second stage regulator (SSR) in a vice and install the reference pressure gauge (27) directly to the main outlet of the regulator ('OUTLET' will be marked on this port) and tighten using a 9/16" open ended spanner on the flats of the gauge (*Important*).
- iv. With the second stage regulator (SSR) in the vice, install the 3" extension piece (28) directly to the main inlet port ('INLET' will be marked on this port) and tighten using a 9/16" open ended spanner.
- v. Place the changeover regulator assembly (CRA, X and CRB) in a vice and then screw the 3" extension piece (28) into the female NPT port which is located on the same side of the assembly as the regulator gauge ports. Tighten using a 9/16" open ended spanner until the second stage regulator (SSR) is of the same orientation as the change over regulators.
- vi. The inlet pressure gauges (27) can now be installed into the gauge ports of CRA and CRB. Tighten using a 9/16" open ended spanner on the flats of the gauge (*Important*).
- viii. The left and right process inlet pipe work assemblies (39, 40, 41, 44, 45) can be installed into each of the changeover regulators whilst securing the changeover regulator assembly in a vice.
- vii. Place the ACS transfer rods (23) into the adjusting screw (22) of each changeover regulator (CRA and CRB).
- viii. The changeover mechanism (1, 2, 3, 4, 6) can then be placed onto the assembly. The bracket should rest on the two lower panel mount rings.
*Note: Ensure the upper mount rings are removed if they were used to prevent movement of the lower mount rings during the service.
- ix. Position the other two panel mount rings (7) onto the assembly and screw onto the bonnet (20) until it is sat close to the changeover bracket (1).
- x. Place the assembly upside down and position the changeover regulator spacers (43) over the three regulators ensuring that the holes line up with the M5 mount holes on the bottom of the regulators.
- xi. Position the panel (37) onto the assembly ensuring that the slots line up with the mount holes and screw the M5 bolts and washers in place.

6.1.5. To Reset the Changeover Mechanism

*Note: Fig 1 should be used as a reference for the following set of instructions

To reset the changeover mechanism, please follow the instruction below:

- i. With the complete changeover system assembly secured in a vice and the changeover bracket in place on the assembly, note the side not 'in service' indicated by the changeover handle (3).
*Note: It is assumed at this stage the side not 'in service' is CRA.
- ii. With the changeover mechanism (1, 2, 3, 4, 6) resting on the lower panel mount ring (7), screw the lower panel mount ring (7) on CRA bonnet (20) clockwise until the underside of the cam (2) is touching the top of the transfer rod (23).
- iii. The upper mount ring (7) should then be tightened against the changeover bracket (1) using a 41mm open ended spanner or adjustable.
*Note: Ensure that the position of the bracket remains central whilst tightening to maintain the best contact area between the cam and the transfer rod
- iv. Then, flip the changeover handle (3) so CRB is not 'in service'.
- v. Repeat step ii. for CRB until the underside of the cam (2) is touching the top of the transfer rod (23).
- vi. Again, the upper mount ring (7) should then be tightened against the changeover bracket (1) using a 41mm open ended spanner or adjustable.
- vii. With the changeover mechanism now secure, flip the changeover handle (3) and ensure that the transfer rods (23) are engaging correctly with the cam (2) on each movement.
*Note: It is useful to monitor the movement of one transfer rod at a time during changeover handle movements.
- viii. Make the necessary adjustments to the upper and lower panel mount rings (7) if it seems that any of the transfer rods (23) are either engaging too much, or not enough with the cam (2).
*Note: This could be observed by the difficulty in movement of the handle. i.e. too difficult would mean too much engagement and too easy may not be enough engagement.

6.1.6. Verifying the Set Point

The set points can be verified by installing a pressure gauge into the port on the connector block.

*Note: It may be necessary to first remove the relief valve in order to do so.

- i. With CRA 'not in service', supply pressure to this regulator only and observe the pressure on the outlet gauge.
- ii. Flip the lever and observe the increase in pressure on the outlet pressure gauge.
- iii. Note the pressure increase and then drain the pressure from this supply.
- iv. Repeat i. to iii. for CRB. The same set pressures should be observed for each regulator both when 'in service' and 'not in service'.

6.1.7. Testing the Changeover System

- i. Confirm that the changeover mechanism has been set correctly by applying pressure (+100bar is recommended) to each of the changeover regulators. The pressure should be evident in PGA and PGB.
- ii. Then isolate each supply, leaving the pressure in each line.
- iii. Assuming that the side 'in service' is CRA, slowly open the second stage regulator (SSR) until the supply pressure can be seen depleting on PGA.
- iv. Whilst the pressure is depleting from supply A, ensure that the pressure in supply B remains constant.
- v. Then, switch the changeover handle (3) to make CRB 'in service'. Ensure that the pressure which was depleting from supply A has stopped and the pressure can now be observed depleting on PGB.
- vi. Whilst the pressure is depleting from supply B, ensure that the pressure in supply A remains constant.
- vii. Allow the pressure to deplete from supply B until it reaches the set point and ensure that the unit then automatically switches to supply A.
- viii. When supply A reaches the set point, the pressure from each supply will then fall simultaneously to zero.
- ix. Repeat steps i. to viii. starting with CRB as the side 'in service'. Ensure that the manual change activates supply A whilst supply B remains constant and that the supply automatically switches from A to B once the set point is reached.

6.1.8. Troubleshooting

The following are examples only. For more information or assistance please contact the office.

Problem	Problem Indicator(s)	Probable Cause(s)	Recommended Action(s) and Correction
Changeover System will not switch supply correctly	Pressure is observed dropping from both pressure gauges	The changeover mechanism may not be set correctly	Refer to 6.1.5. and make the necessary adjustments to the panel mount rings. For example; if the adjustment to make CRB the side 'in service' feels loose, then the panel mount rings should be lowered on CRB to ensure the correct engagement between the transfer rod and cam.
		The changeover regulators may not be set at the correct pressure	Follow the steps in 6.1.6. *Note: It is important to ensure that the changeover regulators are set to the same outlet pressure using the same inlet pressure
The relief valve vents during changeover	The relief valve vents excess pressure during change	The relief valve is set incorrectly (too low or close to the set point)	Ensure that the relief valve is set approximately 2-3 bar above the set point. (typically, the relief valves are set at 23 bar)
The relief valve vents during normal operation	The relief valve vents excess pressure during normal operation	A leak on the changeover regulator(s) would cause a pressure buildup downstream	Perform system strip down as per 6.1.1. and follow the steps in 6.1.2. Ensure that the changeover regulators are shutting off by performing a bubble test at lower inlet pressure prior to setting.

6.1.9. Figure 1 – View of the ACS-300

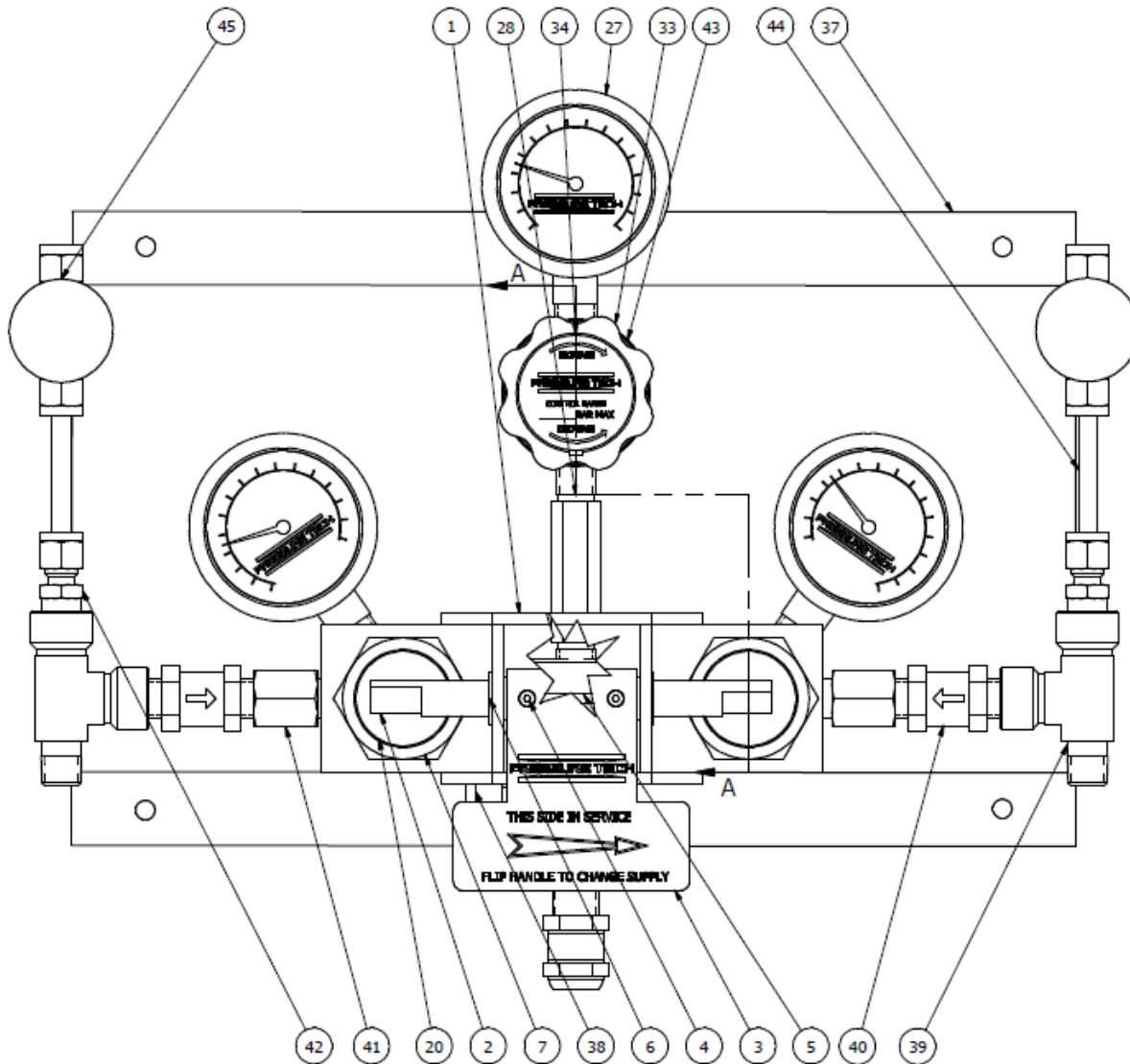

PARTS LIST		
ITEM	PART NUMBER	DESCRIPTION
1	PT-AC-300-002	ACS BRACKET SUPPORT
2	PT-AC-300-003	ACS CHANGEOVER ROD (CAM)
3	PT-AC-300-004	ACS HANDLE
4	FIT-M3-6-A2-SKT-CSK	M3x6 COUNTERSUNK SOCKET SCREW
5	PT-AC-300-008	ACS CONNECTING BLOCK
6	PT-AC-300-012	ACS ROTATING BUSH
7	PT-C-024	PANEL MOUNT RING
20	PT-C-015	BONNET
27	GAU-1100-XXX	PRESSURE GAUGE
28	SLOK-SS-4-HLN-3.00	SWAGELOCK HEX 3" LONG EXTENSION
33	PT-C-021	SMALL HAND WHEEL
34	PT-C-022	NAMEPLATE
37	PT-AC-300-010-001	ACS WALL BRACKET (PANEL)
38	SLOK-SS-4R3A	SWAGELOK RELIEF VALVE
39	SLOK-SS-4-ST	SWAGELOK STREET TEE 1/4"
40	SLOK-SS-4CPA2-50	SWAGELOK CHECK VALVE
41	SLOK-SS-4-A	SWAGELOK 1/4" NPT ADAPTER
42	SLOK-SS-400-1-4	SWAGELOK 1/4" COMPRESSION FITTING
43	PT-AC-300-017	ACS REGULATOR SPACER
44	FIT-T-ACS-04-016-SS	1/4" STAINLESS STEEL TUBE
45	SLOK-SS-1RS4	SWAGELOK

© Copyright of Pressure Tech Ltd

6.1.10. Figure 2 – Sectional View of the ACS-300

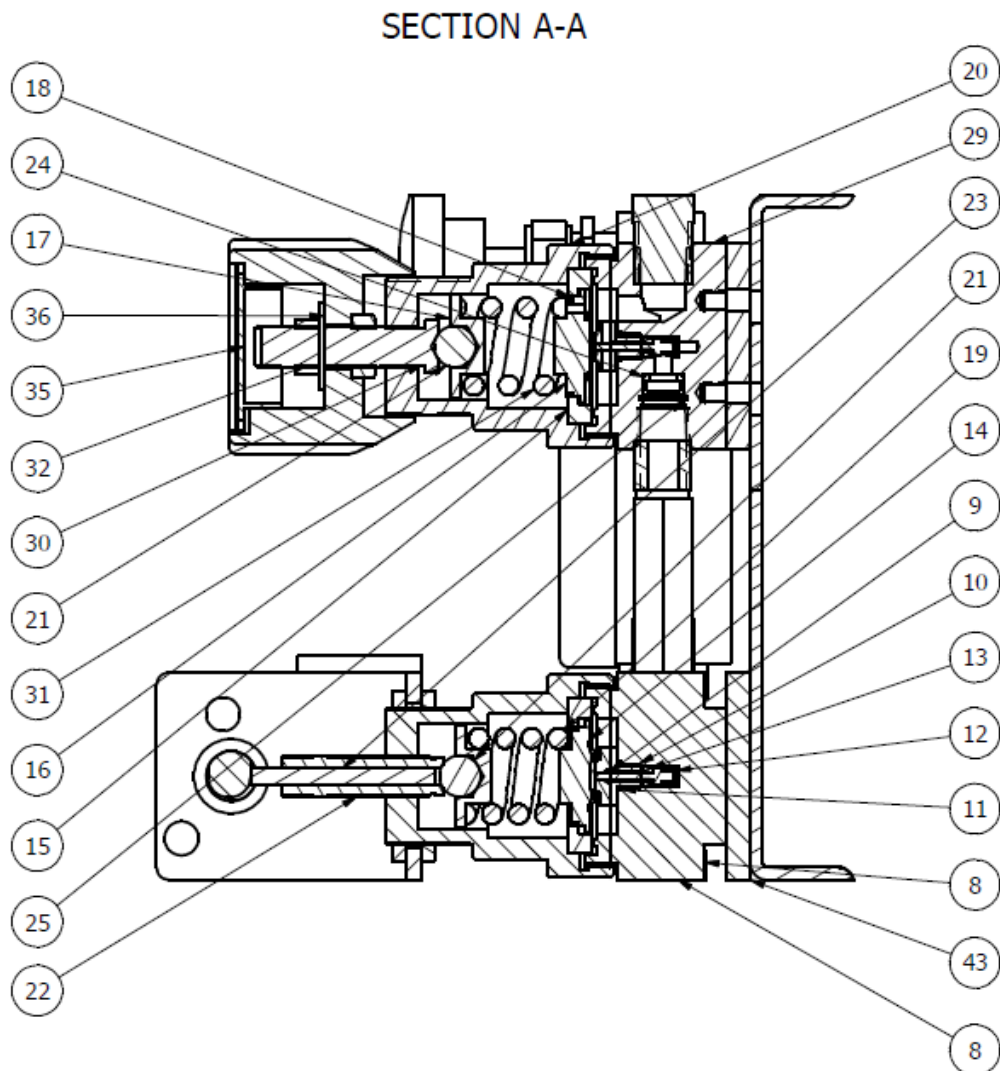

PARTS LIST		
ITEM	PART NUMBER	DESCRIPTION
8	PT-50-G-SS	BODY – 'G' PORTING – 'CRB'
9	PT-C-001-013	MAIN VALVE
10	PT-C-007-002	SEAT Cv 0.06
11	OR-0050-10	O-RING STD
12	PT-C-006-002	MAIN VALVE COMPRESSION SPRING
13	PT-C-002-011	SOFT SEAT (PCTFE)
14	PT-C-010-002	DIAPHRAGM
15	PT-C-016	DIAPHRAGM WASHER
16	PT-C-018-002	LOWER SPRING REST
17	PT-C-017	UPPER SPRING REST
18	OR-0210-10	O-RING STD
19	PT-C-011-001	LOAD SPRING
20	PT-C-015	BONNET
21	BALL-010-SS-316	10MM BALL BEARING
22	PT-AC-300-006	ADJUSTING SCREW
23	PT-AC-300-007	ACS TRANSFER ROD
24	FILT-SCRM31040405-A	10MM DIA SCREEN FILTER
25	CIR-BS3673/1 – B010M	CIRCLIP
26*	PT-50-U-SS	BODY – 'U' PORTING – 'CRA' (not shown)
29	PT-50-C-SS	BODY – 'C' PORTING – 'SSR'
30	PT-C-019-003	ADJUSTING SCREW
31	PT-C-011-004	LOAD SPRING
32	PT-C-020	LOCKNUT
35	PT-C-021	SMALL HAND WHEEL
36	PT-C-022	NAMEPLATE
43	PT-AC-300-017	ACS REGULATOR SPACER

7. Technical Data

Fluid Media:	All gases and liquids compatible with materials of construction
Max Inlet Pressure ¹ :	300 bar (4350 Psi) (with PEEK Seat) 210 bar (3000 Psi) (with PCTFE Seat)
Outlet Pressure Range ² :	First stage: Set at 20 bar (changeover pressure) Second Stage: 0 – 10 bar
Operating Temperature:	-20°C to +80°C
Materials:	Body and Trim: 316 SS Diaphragm: Inconel X750 Seat: PCTFE / PEEK® / PTFE / FEP
Flow Capacity (Cv):	0.06
Leakage:	Gas: Bubble tight Liquid: Zero drops of water at max inlet

1. The Max Inlet Pressure determined by seat material and Cv of regulator.
 2. The Standard Outlet Pressure Range for this regulator. Please contact the office for further options.
- *Note: The changeover pressure becomes the supply pressure for the second stage regulator.

8. Warranty Statement

Pressure Tech Ltd guarantee all products correspond with their specification at the time of delivery and, with exception to wear and tear, wilful damage, negligence, and abnormal working conditions, will be free from defects for a period of 12 months from date of delivery.

Annex A. LF-310 – ‘Solid Disk’ Main Valve Design

A.1. Description

The ‘solid disk’ type main valve assembly was introduced as an alternative to the unique ‘cone type’ assembly and could be applied where greater resistance to both temperature and pressure were required. The new disk design allows for a wider range of seat material options as well as increased Cv and Pressure combinations.

The model number ‘LF-310’ was assigned to denote the requirement for the new disk type main valve arrangement. The LF-310 ‘solid disk’ option allows for a Maximum Working Pressure of 300 Bar (4350 Psi) or 414 bar (6000 Psi) when fitted with a PEEK seat. The LF-310 is capable of accurately controlling pressures of up to 35 bar (510 Psi).

A.2. Servicing

The servicing of the LF-310 regulator should be performed in line with the service instructions for the LF-300 as defined in Section 6 of this manual, taking account for the difference in valve assembly. The figures below detail the alternate main valve assembly for reference purposes only.

A.2.1. Figure 2 – Detail A: LF-310 ‘Solid Disk’ MVA (sectional)

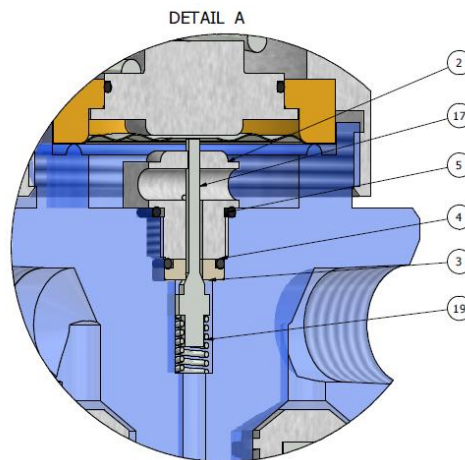

A.2.2. Figure 3 – Exploded View of LF-310 ‘Solid Disk’ MVA

