



THE LF-792 SERIES

Operating and Service Manual

Series includes all variants of LF-792

Issue B
NOV 2019



TABLE OF CONTENTS

1. Description	3
2. Installation	3
3. Operation	4
4. Special Conditions for Safe Use	5
5. Hazardous Location Usage	5
6. Servicing and Maintenance.....	5
6.1. Servicing Main Valve Assembly	6
6.1.1. Accessing the Main Valve Assembly (MVA)	6
6.1.2. Accessing the Sensing Assembly (SA) – Dome Top	7
6.1.3. Figure 1 – Section view of the LF-792 - Domed SA/Unbalanced MVA...9	
6.2.1. Accessing the Balanced Main Valve Assembly (MVA).....	10
6.2.2. Accessing a Threaded Sensing Assembly (SA) - Threaded	11
6.2.3 Figure 2 – Section view of the LF-792 - Threaded SA/Balanced MVA...12	
7. Technical Data.....	13
8. Warranty Statement	15

1. Description

The LF-792 is a single stage piston sensed pressure regulator for gas applications, capable of a maximum 1034 bar inlet pressure. This can then be controlled to a range of outlet pressures depending upon the sensing arrangement and loading mechanism. As standard, the LF-792 comes with a Tecasint seat for regulators (with Cv 0.1/0.05) and 316-SS main valve, which provides a positive shut off and can withstand 1034 bar working pressure.

The balanced designed regulators (with Cv 0.3) are supplied with PEEK and 316-SS main valve, as standard, which provides a positive shut off and can withstand 690 bar working pressure. This also allows for high accuracy control of both low and high downstream pressures, depending upon the sensing arrangement and loading mechanism.

2. Installation

Before system start-up, it is recommended that all systems be pressure tested, leak tested and purged with an inert gas such as nitrogen.

Prior to placing into service ensure that the regulator is in the fully closed position, with the adjusting mechanism turned completely anti-clockwise.

Check the model number reference to ensure that the pressure range complies with the installation requirements.

Visually inspect the regulator for any signs of damage or contamination. If any foreign materials are present and cannot be removed from the regulator, or if the threads on the regulator appear to be damaged, please contact the office immediately to arrange for the regulator to be returned for service.

The Inlet and Outlet ports are clearly marked. Select the correct size and type of connection fittings for these ports which are indicated in the regulators part number. Both medium pressure type (MP) 'A' and National Pipe Thread (NPT) 'N' options are available on this regulator. For NPT threads, ensure that PTFE tape is applied correctly to the fittings, applying two overlapping layers in the direction of the thread, taking care that the tape does not come into contact with the first thread.

Any gauge ports on the regulator will be 1/4" NPT unless otherwise stated. If any gauge port is not required, ensure that the port is plugged prior to installation.

The media supplied to the regulator must be clean. Contamination can damage the seat which may cause the regulator to fail. Filtration suited to the application is recommended upstream of the regulator.

Should further assistance or information be required in relation to installation of any Pressure Tech regulator please contact the office, giving reference to the regulators part number and/or serial number.

3. Operation

Gradually turning the hand wheel clockwise compresses the load spring, which in turn opens the main valve, and allows the inlet pressure to pass through the orifice until the outlet pressure is equivalent to the loading forces set by the compressed spring.

Gradually increasing an air supply to the top air actuated bonnet, applies pressure across the diaphragm, which in turn opens the main valve, and allows the inlet pressure to pass through the orifice until the outlet pressure is equivalent to the loading forces set by the compressed spring.

The LF-792 incorporates a segregated captured vent (1/4" NPT), which allows the outlet pressure to be reduced whilst turning the hand wheel anti-clockwise. Excess pressure is exhausted via the 'Vent' port marked at the bottom of the regulator and piped to tank or other facility. Note that safe, inert gases may vent to atmosphere if required. For Non-venting (NV) regulators, the excess pressure will not vent through the 'Vent' Port and should be vented downstream of the regulator. Ref Section 4.

Important: The vent port should not be plugged or blocked at any time.

The LF-792 series may be offered with pressure limiting, pressure locking or pre-set pressure options:

Pressure limited regulators are fitted with locknuts on the adjusting mechanism in order to limit the maximum allowable downstream pressure. Regulators fitted with pressure limiting locknuts will state the limited pressure on the regulator label and this will also be indicated in the part number.

Pressure locking regulators are fitted with a locking cap which may be set (when specified) to pre-determined requirements. It is secured in place by three M5 grub screws which lock against the bonnet of the regulator creating an anti-tamper device to ensure the pressure cannot be adjusted accidentally.

Pre-set pressure regulators are adjusted (factory set) to specified customer requirements within a given pressure range.

Both pressure locking and pre-set pressure regulators will be fully adjustable through a given pressure range and the maximum allowable working pressures will be indicated on the regulator label and in the part number.

*Note - A table is available on request defining allowable tolerances for set points within a given pressure range.

4. Special Conditions for Safe Use

Turning the hand wheel anti-clockwise (with pressure on the outlet) should be refrained on non-venting regulators. Pressure should be gradually reduced in this case by venting downstream of the regulator and turning the hand wheel simultaneously anti-clockwise.

For Air Actuated Regulators: Depressurizing the air supply to the actuator bonnet (with pressure on the outlet) should be refrained on non-venting regulators. Pressure should be gradually reduced in this case by venting downstream of the regulator and simultaneously reducing the air supply gradually, to the actuator bonnet.

5. Hazardous Location Usage

This equipment has not been manufactured specifically for use in potentially explosive atmospheres and as such an ignition hazard assessment has not been carried out on this product. If the user should wish to use this product in such an environment where there may be a potentially explosive atmosphere, then it is the responsibility of the user to conduct an ignition hazard assessment.

6. Servicing and Maintenance

The product supplied may vary from the examples covered by this manual. Should any assistance be required then please do not hesitate to contact the office.

Servicing and maintenance work on the LF-792 regulators should only be performed after fully reading and understanding the Operating and Servicing Manual. Due to the compressibility of gases, the operator should not endanger himself/herself or others by working on this regulator without prior knowledge of the Health and Safety risks relating to handling of technical gases. Any uncertainty should be clarified with Pressure Tech before working on the regulator.

Pressure Tech Ltd recommends the use of Krytox GPL 205, as a lubricant for O-rings and Molykote 1000 paste for the adjusting screw, during servicing.

Prior to commencing service, please ensure that:

- The equipment has been de-pressurised
- The load spring has been de-compressed by turning the adjusting mechanism fully anti-clockwise
- The air actuator bonnet has been de-pressurised
- Applications involving toxic, flammable or corrosive media have been fully purged

To ensure the best possible results from servicing, when re-assembling the regulator and any assemblies within it, ensure that all areas of the components and the regulator body are cleaned and free from contaminants which may result in failure of the regulator.

6.1. Servicing Main Valve Assembly

6.1.1. Accessing the Main Valve Assembly (MVA)

*Note: Figure 1 should be used as a reference for the following set of instructions

To access the Main Valve Assembly:

- i. Firmly clamp the flats at the bottom of the regulator in the vice, with the bottom nut (15) facing up.
- ii. Remove the bottom nut (15) from the body (17).
- iii. The valve spring (33), main valve (27), seat cartridge (28) and soft seat (35) can now be removed from the assembly.
Note: It may be necessary to remove the regulator from the vice to do so.
- iv. The connector pin (16) may also be withdrawn at this point by up righting the regulator with the main valve assembly removed.
Note: Care should be taken when reassembling not to damage the sealing face of the connector pin (16).
- v. Use needle nose pliers to replace the connector pin chamfer down into the body, while the body is up-side down. The pin should locate within the baffle plate (26).
- vi. The new soft seat (35) should be placed in the seat cartridge (28) with the BS 806 'O' ring (14).
- vii. These can then be placed into the regulator body, being careful to ensure that the BS 806 'O' ring (14) remains in place and that the seat cartridge (28) locates in the correct place within the body (17).
- viii. The main valve (27) can then be placed within the seat cartridge (28).
- ix. The main valve spring (33) can now be placed on the stem of the main valve (27).
- x. Replace the BS019 'O' ring (13) and back up ring (10) on the bottom nut (15), then assemble into the regulator body.
- xi. Use a torque wrench, tighten the bottom nut (15) against the body (17) to 40Nm.

It is recommended that all parts in the repair kits are used. Any defect parts removed during the service should be disposed of.

To ensure that the main valve assembly has been correctly and effectively installed it may be required to perform the appropriate seat leak test as per ANSI/FCI 70-2

6.1.2. Accessing the Sensing Assembly (SA) – Dome Top

The loading mechanism and vent seat for the LF-792 can be accessed from the top of the regulator. Ensure the spring is de-compressed by rotating the hand wheel fully anti-clockwise and follow the instructions below:

*Note: Figure 1 should be used as a reference for the following set of instructions

- i. Remove the securing grub screw (3) from the regulator body (17).
- ii. Unscrew the pan screw (2) and remove the name plate (25) from the hand wheel (24).
- iii. Using a 24mm socket, unscrew the locknut (34) and remove the hand wheel (24) from the adjusting screw (21).
- iv. With the regulator secured up-right in a vice, remove the bonnet (19) by using a torque wrench or equivalent with 47mm open end.
- v. Un-screw and lift the top works from the assembly, inclusive of the bonnet (19) and adjusting mechanism (1,7,20-23 & 32) from the body.
- vi. Remove the lower spring rest (32) from the bonnet.
- vii. Remove the 35mm x 2mm 'O' ring (7), from the lower spring rest and replace, ensuring adequate lubrication is used.
- viii. Remove the load spring (20).
- ix. The sensor assembly (4-6,8,9,11,12,18 & 29-31) can be removed from the body by screwing an M5x08 bolt, into the M5 threaded bore situated on the top of the sensor holder and then firmly grip the bolt with pliers and lift.
- x. If necessary, the baffle plate (26) and connector (16) can be withdrawn. Inspect the connector for damage and replace if required.
- xi. The vent seat (18) can be accessed by removing the sensor (31) from the sensor holder (30) and gripping the flats at the base of the sensor firmly in a vice with the vent seat nut (29) facing upwards.
- xii. The vent seat nut (29) can be removed using a 10mm open ended spanner and the vent seat (18) can then be removed from the sensor (31) along with the 9mm x 1mm 'O' ring (5).
- xiii. Inspect the vent seat (18) for damage and replace, along with the new 9mm x 1mm 'O' ring (5).
- xiv. Secure the vent seat nut (29) using a 10mm open ended spanner.
- xv. Replace all 'O' rings (4,6,8 & 9) located on the sensor (31) and within the sensor holder (30) prior to reassembly, ensuring adequate lubrication is used.
- xvi. Place the connector pin (16) into the baffle plate (26) and locate into the regulator body, taking care not to damage the sealing edge of the connector.
- xvii. After reassembling the sensor assembly, place into the regulator body (17) ensuring that it is firmly in place.
- xviii. Remove the M5 screw from the sensor holder (30) if used.

- xix. Place the lower spring rest (32) with 32mm x 2mm 'O' ring (7), onto the load spring (20) within the bonnet (19).
- xx. Screw the top works onto the regulator body and using a torque wrench or equivalent with 47mm open end, tighten to 120Nm.
- xxi. Tighten the securing grub screw (3) against the bonnet (19).
- xxii. The hand wheel (24) can now be secured on to the adjusting screw (21) using the locknut (34).
- xxiii. The name plate (25) can then be secured using the pan screw (2).

6.1.3. Figure 1 – Section view of the LF-792 - Domed SA/Unbalanced MVA

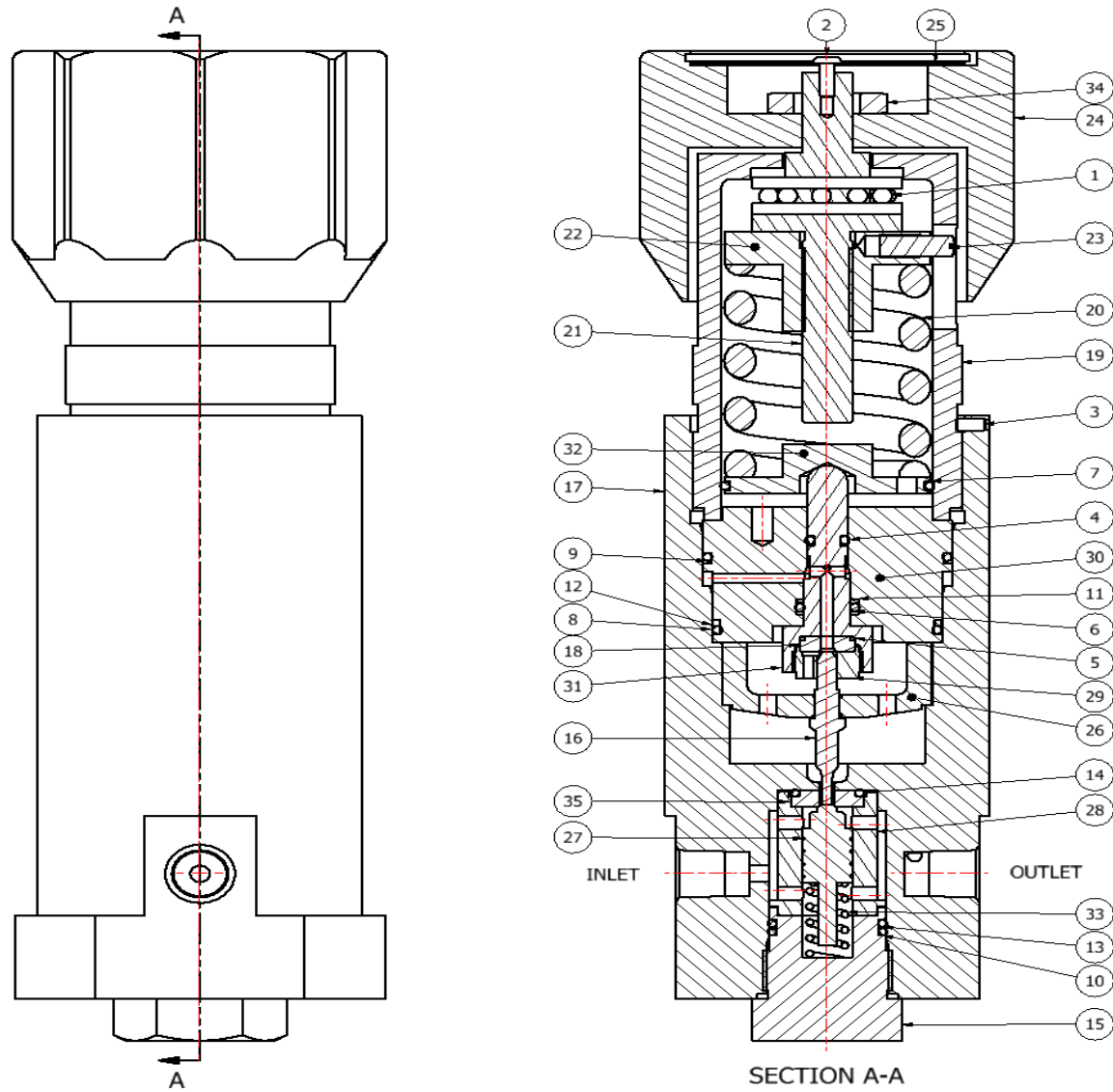

PARTS LIST		
ITEM	PART NUMBER	DESCRIPTION
1	BEAR-51103-SS	SS BEARING
2	FIT-M3-08-A4-70.0-SKT-BTN	SOCKET BUTTON SCREW
3	FIT-M3x6MM-SS-316-GRUBSCRW	M3 X 6mm GRUB SCREW
4	OR-0050-20	O' RING STD
5	OR-0090-10	O' RING STD
6	OR-0090-20	O' RING STD
7	OR-0350-20	O' RING STD
8	OR-0420-20	O' RING STD
9	OR-0460-20	O' RING STD
10	ORB-BS019	BACK UP RING
11	ORB-PT-C-098-005	BACK UP RING
12	ORB-PT-C-139	BACK UP RING
13	OR-BS019	O' RING STD
14	OR-BS806	O' RING STD
15	PT-690-010	BODY NUT
16	PT-690-011-018	CONNECTOR PIN
17	PT-690-N-LF-02N-002	BODY
18	PT-C-029-013	PEEK VENT SEAT GF30
19	PT-C-040	BONNET
20	PT-C-042	500KG LOAD SPRING
21	PT-C-043-004	ADJUSTING SCREW
22	PT-C-045	ADJUSTING NUT
23	PT-C-046	ADJUSTING NUT SCREW
24	PT-C-048-001	LARGE NYLON HAND WHEEL
25	PT-C-049	NAMEPLATE
26	PT-C-086	BAFFLE PLATE
27	PT-C-088-013	MAIN VALVE
28	PT-C-089-008	SEAT HOLDER
29	PT-C-091	VENT SEAT NUT
30	PT-C-093-002	SENSOR HOLDER 9mm
31	PT-C-094-002	9mm SENSOR
32	PT-C-095-001	SPRING REST - DOME
33	PT-C-099	MAIN VALVE SPRING
34	PT-C-132	LOCK NUT
35	PT-C-249	TECASINT SEAT

© Copyright of Pressure Tech Ltd

6.2.1. Accessing the Balanced Main Valve Assembly (MVA)

*Note: Figure 2 should be used as a reference for the following set of instructions

To access the Main Valve Assembly:

- i. Firmly clamp the flats at the bottom of the regulator in the vice, with the bottom nut (18) facing up. Remove the bottom nut (18) from the body (22).
- ii. The main valve spring (17), seat cartridge (27), main valve (36), washer (20), PTFE spacer (21), and 'O' rings (14,15,16) can then be removed from the assembly.
Note: It may be necessary to remove the regulator from the vice to do so.
- iii. The connector pin (19) may also be withdrawn at this point using needle nosed pliers or by up righting the regulator with the main valve assembly removed.
Note: Care should be taken when reassembling not to damage the sealing face of the connector pin (19).
- iv. Use needle nose pliers to replace the connector pin chamfer down into the body while the body is up-side down. The pin should locate within the baffle plate (34).
- v. Place the soft seat (40) into the seat cartridge (37) with the 'O' ring groove on the seat facing outwards and place the BS806 'O' ring (15) into the groove.
- vi. Holding the regulator upright, position the assembly (15,37,40) into the regulator body (22) ensuring that it finds the locating bore, then turn the regulator body (22) upside down whilst supporting the assembly (15,37,40) to ensure it does not fall out of place.
- vii. Replace all of the seals (14 & 16) on the bottom nut *(18).
- viii. Place the washer (20) into the small recess, on the top of the bottom nut (18).
- ix. Place/push the PTFE spacer (21), into the upper bore of the bottom nut (18)
- x. **Note:** Add a small amount of Krytox lubricant to the underside of the PTFE spacer (21), before placing into the bottom nut (18). This is to help the PTFE spacer from coming away from the bottom nut, during assembly into the regulator body (22).
- xi. Guide the main valve spring (17), over the stem of the main valve (36).
- xii. Guide/place the main valve (36) and the main valve spring (17), into the central bore of the bottom nut (18) and seated onto the washer (20). (which acts as a lower spring rest).
- xiii. With the regulator remaining upside down, guide the full bottom nut assembly (4,10,13-18,20,21,36,37,40), with the main valve (36), leading into the central bore of the seat cartridge (37) and screw the bottom nut (18) into the regulator body (22)

**The small back up ring (13) should be placed into the bottom nut (18) first, followed by the 3.6mm 'O' ring (4)

6.2.2. Accessing a Threaded Sensing Assembly (SA) - Threaded

The loading mechanism and vent seat for the LF-792 can be accessed from the top of the regulator. Ensure the spring is de-compressed by rotating the hand wheel fully anti-clockwise and follow the instructions below:

*Note: Figure 2 should be used as a reference for the following set of instructions

- i. Remove the securing grub screw (3) from the regulator body (22).
- ii. Unscrew the pan screw (2) and remove the name plate (31) from the hand wheel (31).
- iii. Using a 24mm socket, unscrew the locknut (39) and remove the hand wheel (31) from the adjusting screw (28).
- iv. With the regulator secured up-right in a vice, remove the bonnet (26) by using a torque wrench or equivalent with 47mm open end.
- v. Un-screw and lift the top works from the assembly, inclusive of the bonnet (26) and adjusting mechanism (1, 28, 29 & 30) from the body.
- vi. Remove the load spring (27).
- vii. The sensor assembly (5-9,11,12,23-25,33,35 & 38) can be removed from the body by firmly gripping the flats of the lower spring rest with pliers and lifting.
- viii. If necessary, the baffle plate (34) and connector pin (19) can be withdrawn. Inspect the connector for damage and replace if required.
- ix. Grip the flats of the lower spring rest (25) in a vice so that the vent seat nut (38) is facing.
- x. The vent seat nut (28) can be removed using a 10mm open ended spanner and the vent seat (23) can then be removed from the sensor (35) along with the 9mm x 1mm 'O' ring (6).
- xi. Inspect the vent seat (23) for damage and replace.
- xii. The sensor (35) can then be unscrewed from the lower spring rest (25) and the sensor can then be removed from the sensor holder (33).
- xiii. Replace all 'O' rings (5 & 7-9) located on the sensor (35) and sensor holder (33) prior to reassembly, ensuring adequate lubrication is used.
- xiv. Insert the sensor (35) into the sensor holder (33).
- xv. Apply a small droplet of Loctite 638, to the thread of the lower spring rest and screw the lower spring rest (25) into the top of the sensor (35).
- xvi. Grip the flats of the lower spring rest (25) in a vice and tighten the sensor (35) against it using the flats at the base of the sensor.
- xvii. Secure the vent seat nut (38) using a 10mm open ended spanner.
- xviii. Place the connector (19) into the baffle plate (34) and locate into the regulator body, taking care not to damage the sealing edge of the connector.
- xix. After reassembling the sensor assembly, place into the regulator body (22) ensuring that it is firmly in place.
- xx. Place the load spring (27) onto the spring rest (25).
- xxi. Screw the top works (1, 26, 28, 29 & 30) onto the regulator body ensuring that the adjusting screw properly locates within the load spring and using a torque wrench, tighten to 120Nm.
- xxii. Tighten the securing grub screw (3) against the bonnet (26).
- xxiii. The hand wheel (31) can now be secured on to the adjusting screw (28) using the locknut (39).
- xxiv. The name plate (31) can then be secured using the pan screw (2).

6.2.3 Figure 2 – Section view of the LF-792 - Threaded SA/Balanced MVA

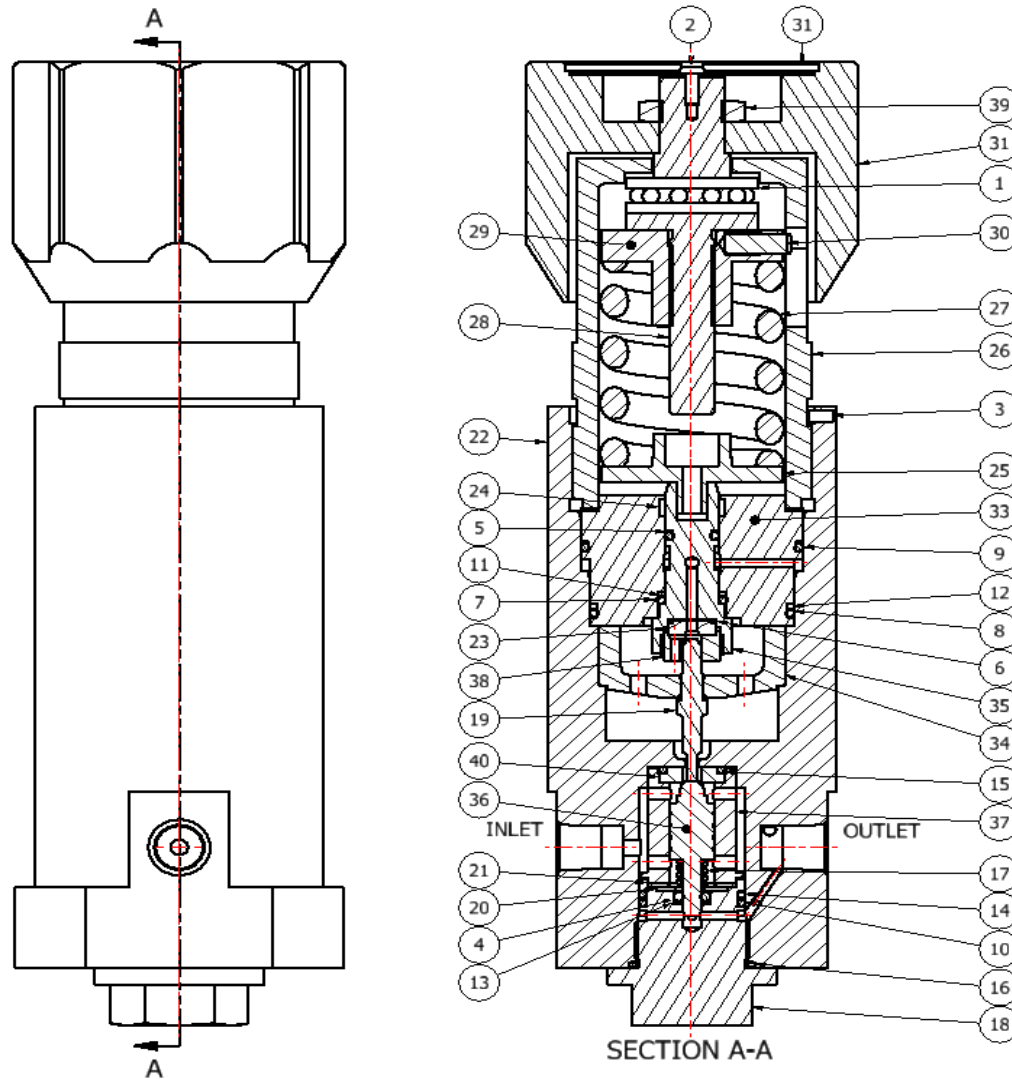

PARTS LIST		
ITEM	PART NUMBER	DESCRIPTION
1	BEAR-51103-SS	SS BEARING
2	FIT-M3-08-A4-70.0-SKT-BTN	SOCKET BUTTON SCREW
3	FIT-M3x6MM-SS-316-GRUBSCRW	M3 X 6mm GRUB SCREW
4	OR-0036-24	O' RING STD
5	OR-0080-20	O' RING STD
6	OR-0090-10	O' RING STD
7	OR-0120-20	O' RING STD
8	OR-0420-20	O' RING STD
9	OR-0460-20	O' RING STD
10	ORB-BS019-PTFE	PTFE BACK UP RING
11	ORB-PT-C-051-001	BACK UP RING
12	ORB-PT-C-139	PTFE BACK UP RING
13	ORB-PT-C-183	BACK UP RING
14	OR-BS019	O' RING STD
15	OR-BS806	O' RING STD
16	OR-BS4518-0251-16	O' RING STD
17	PT-690-004	MAIN VALVE SPRING
18	PT-690-010-001	BOTTOM BODY NUT
19	PT-690-011-013	CONNECTOR PIN
20	PT-690-020	WASHER
21	PT-690-041	PTFE SPACER
22	PT-792-N-LF-02N-001	BODY - BALANCED
23	PT-C-029-013	PEEK VENT SEAT GF30
24	PT-C-037	SLIDE RING
25	PT-C-039	SPRING REST
26	PT-C-040	BONNET
27	PT-C-042	500KG LOAD SPRING
28	PT-C-043-004	ADJUSTING SCREW
29	PT-C-045	ADJUSTING NUT
30	PT-C-046	ADJUSTING NUT SCREW
31	PT-C-048-001	LARGE NYLON HAND WHEEL
32	PT-C-049	NAMEPLATE
33	PT-C-085	SENSOR HOLDER
34	PT-C-086	BAFFLE PLATE
35	PT-C-087	12mm SENSOR
36	PT-C-088-010	BALANCED MAIN VALVE CV 0.3
37	PT-C-089-XXX	SEAT HOLDER
38	PT-C-091	VENT SEAT NUT
39	PT-C-132	LOCK NUT
40	PT-C-251	TECASINT SEAT - BALANCED

© Copyright of Pressure Tech Ltd

6.3.1. Accessing the Air Actuator Bonnet Assembly – Threaded

The Air Actuated bonnet mechanism for the LF-792 can be accessed from the top of the regulator. Ensure the air supply to the Actuator Bonnet is fully depleted, before carrying and following instructions below:

*Note: Figure 3 should be used as a reference for the following set of instructions

- i. Remove the securing grub screw (2) from the regulator body (26), using a 2mm Allen key.
- ii. Place the regulator up-right in a vice and secured against the flats of the body, remove the bonnet (29) by using a wrench or equivalent with 60mm open end.
- iii. Un-screw and lift the Actuator Bonnet Assembly, inclusive of (1,3-6,11,29-35) from the regulator body.
- iv. Place the Actuator Bonnet Assembly up-right in a vice and secure against the flats of the bonnet (29)
- v. Un-screw and remove the 8x M5 Cap Head bolts (3) and spring washers (4), using an M4 Allen key socket.
- vi. Remove the Actuator Top Cover (30) and Inspect the Diaphragm (32) for damage and replace if necessary.
- vii. Lift and remove the Diaphragm Support Plate (33), inclusive of (5 & 34) from the Lower bonnet assembly (1,6,11,29,31,35).
- viii. Remove the Conical Actuator Spring (35) and turn the bonnet upside down, so that the base of the bonnet is facing upwards.
- ix. Remove and Inspect the OR-0150-20 O-ring (11) for damage and replace if necessary.

Re-Assembly

- x. Apply a small amount of PTFE lubricant to the OR-0150-20 O-ring (11) and place into the O-ring groove within the base of the Actuator bonnet (29)
- xi. Place the Actuator Bonnet up-right in a vice and secure against the flats of the bonnet (29)
- xii. Place/locate the Conical Actuator Spring (35) onto the Actuator Base (31) and above the central bore over the top
- xiii. Apply a small amount of PTFE lubricant around the Air Connector (34) and Insert the Air Connector inclusive of (5 & 33), through the centre of the Conical Actuator Spring (35) and into the central bore of the lower bonnet assembly (1,6,11,29,31).
- xiv. Once located into place, press the Diaphragm Support Plate (33) up and down, to check for clear signs of movement.
- xv. Place the Diaphragm (32), onto the Actuator Base (31) and Aline the P.C.D holes of both parts.
- xvi. Place the Actuator Top Cover (30), onto the Diaphragm (32) Aline the P.C.D holes of both parts.
- xvii. Screw/tighten the 8x M5 Cap Head bolts (3) and spring washers (4), into the P.C.D Holes, using a torque wrench with a M4 Allen key socket and torque to 5Nm.
- xviii. Place the regulator up-right in a vice and secured against the flats of the body. remove the bonnet (29) by using a wrench or equivalent with 60mm open end.
- xix. Screw the Actuator Bonnet Assembly, inclusive of (1,3-6,11,29-35) into the regulator body and tighten, using a wrench or equivalent with 60mm open end.
- xx. Screw the securing grub screw (2) into the regulator body (26), using a 2mm Allen key.

6.3.2 Figure 3 – Section view of the LF-792 – Air Actuator Bonnet/Threaded SA/Balanced MVA

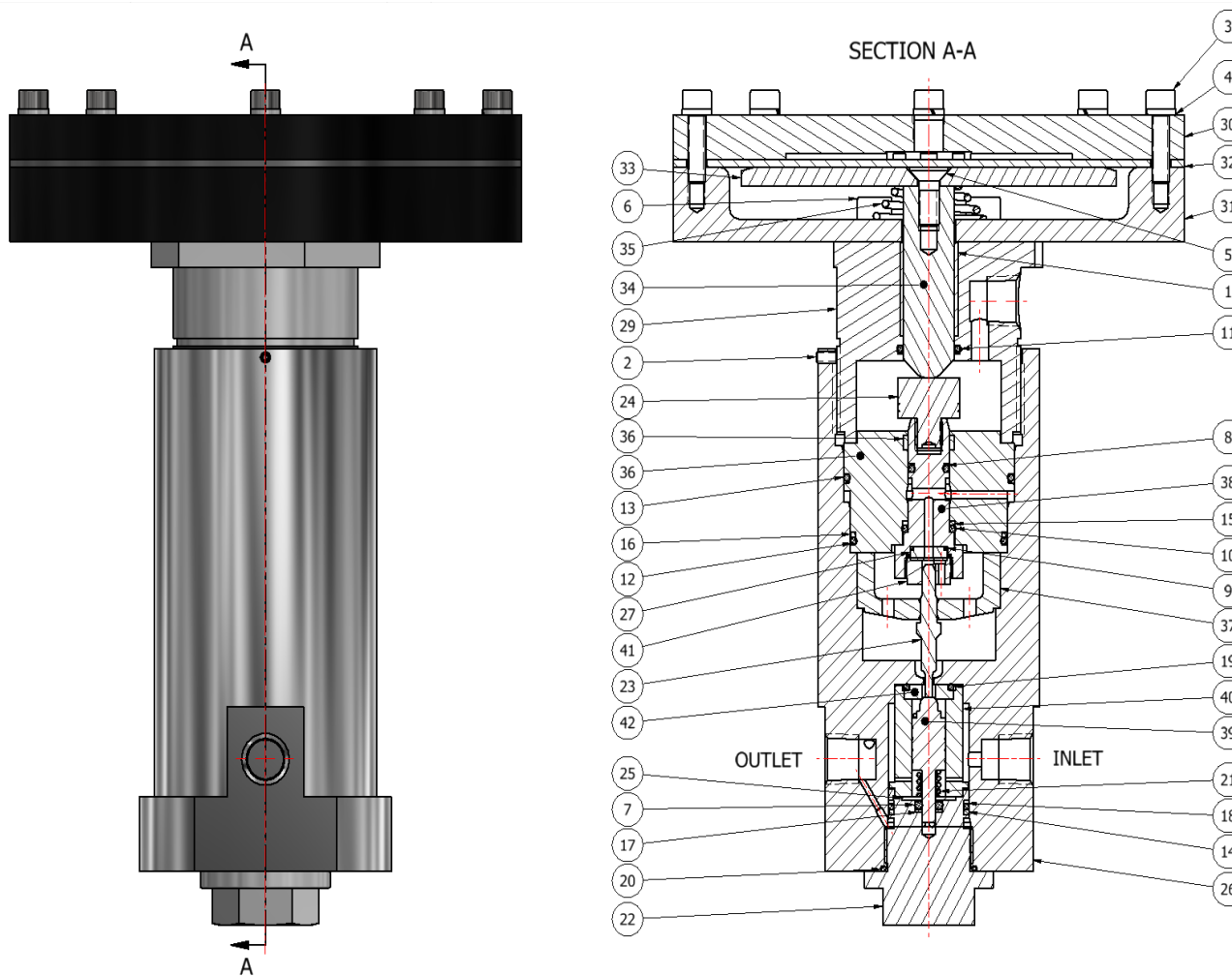

PARTS LIST			
ITEM	QTY	PART NUMBER	DESCRIPTION
1	1	BUSH-1525DU	GLACIER DU BUSH
2	1	FIT-M3x6MM-SS-316-GRUBSCRW	M3 X 6mm GRUB SCREW
3	8	FIT-M5-25-A4-70.0-SKT-CAP	M5 x 20mm CAP SCREW
4	8	FIT-M5-SS-A4-SPR-WASHER	SPRING WASHER
5	1	FIT-M6-16-A4-70.0-SKT-CSK	M6 x 16mm SS316 COUNTERSUNK SCREW
6	4	FIT-M6-20-A4-70.0-SKT-CAP	M6 x 20mm SOCKET HEAD CAP SCREW
7	1	OR-0036-24	O' RING STD
8	1	OR-0080-20	O' RING STD
9	1	OR-0090-10	O' RING STD
10	1	OR-0120-20	O' RING STD
11	1	OR-0150-20	O' RING STD
12	1	OR-0420-20	O' RING STD
13	1	OR-0460-20	O' RING STD
14	1	ORB-BS019-PTFE	PTFE BACK UP RING
15	1	ORB-PT-C-051-001	BACK UP RING
16	1	ORB-PT-C-139	PTFE BACK UP RING
17	1	ORB-PT-C-183	BACK UP RING
18	1	OR-BS019	O' RING STD
19	1	OR-B5806	O' RING STD
20	1	OR-B54518-0251-16	O' RING STD
21	1	PT-690-004	MAIN VALVE SPRING
22	1	PT-690-010-001	BOTTOM BODY NUT
23	1	PT-690-011-013	CONNECTOR PIN
24	1	PT-690-012-003	AIR ADAPTOR
25	1	PT-690-020	WASHER
26	1	PT-792-N-LF-02N-001	BODY - BALANCED
27	1	PT-C-029-013	PEEK VENT SEAT GF30
28	1	PT-C-037	SLIDE RING
29	1	PT-C-053	ACTUATOR BONNET
30	1	PT-C-054	ACTUATOR TOP COVER
31	1	PT-C-055	ACTUATOR BASE
32	1	PT-C-056	DIAPHRAGM
33	1	PT-C-057	DIAPHRAGM SUPPORT PLATE
34	1	PT-C-058	AIR CONNECTOR
35	1	PT-C-060	CONICAL ACTUATOR SPRING
36	1	PT-C-085	SENSOR HOLDER
37	1	PT-C-086	BAFFLE PLATE
38	1	PT-C-087	12mm SENSOR
39	1	PT-C-088-010	BALANCED MAIN VALVE CV 0.3
40	1	PT-C-089-XXX	SEAT RETAINER
41	1	PT-C-091	VENT SEAT NUT
42	1	PT-C-251	TECASINT SEAT - BALANCED

© Copyright of Pressure Tech Ltd

7. Technical Data

Fluid Media:	All gases compatible with materials of construction
Max Inlet Pressure:	Standard: 1034 bar Balanced: 690 bar
Max Outlet Pressure Range:	standard: 0 – 1034 bar Balanced: 0 – 690 bar
Operating Temperature:	-15°C to +80°C
Materials:	Body and Trim: 316 SS Seat: Terasint 2011 or PEEK 450G
Flow Capacity (Cv):	Standard – 0.1 High Pressure – 0.05 Balanced – 0.3
Leakage:	Gas: Bubble tight (ANSI/FCI 70-2)

8. Warranty Statement

Pressure Tech Ltd guarantee all products correspond with their specification at the time of delivery and with exception to wear and tear, wilful damage, negligence, and abnormal working conditions, will be free from defects for a period of 12 months from date of delivery.