

XHR-301 Series

'Low Flow' Electric and Steam Heated Regulator Piston Sensed for outlet control to 150bar / 2175psi

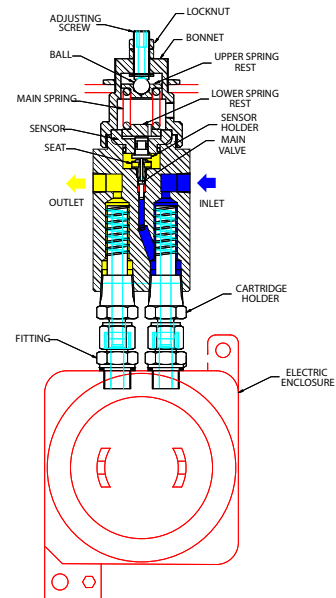

Assembly drawing for reference only. Refer to office for specific detail

Based on the proven heat transfer design of the XHR-300, the XHR-301 allows greater outlet pressures to 150bar via its piston sensed element.

Applications:

- Natural Gas sample systems
- Oxygen sample systems
- Moisture sample system

Features:

ATEX certified to EEx d IIC T3
 Dual, independent, 100W heaters for pre heat and re-heat of sample gas.
 316SS Piston sensed element for low torque adjustment and high pressure control
 Large surface area for heat transfer
 Easy to wire circuit board with 115V or 230V supply
 Stylish Junction Box with 7mm mounting supports.
 Fully serviceable design
 Optional entry points for cable supply

STANDARD MATERIALS OF CONSTRUCTION

Regulator part	Material
Body and Bonnet	316SS
Main valve pin	316SS
Soft seat cone	PEEK
Valve spring	Inconel X750
Piston	316SS
Sensor Holder	316SS
Diaphragm washer	Brass
Cartridge Holder	316SS
'O' ring seals	Viton
Adjusting screw	Alsi Bronze
Electric Enclosure	Coated Aluminium
Compression Fitting	316SS
Lubricant	Krytox GPL 205
Regulator part	Material
Body and Bonnet	316SS

NOTE: Product availability and specifications contained herein are subject to change without notice. Consult local distributor or factory for potential revisions and/or service related issues. // pg 1 of 2

PRESSURE TECH LTD, Unit 6, Graphite Way, Hadfield, Glossop, Derbyshire SK13 1QG
 Tel: +44 (0)1457 899307 Fax: +44 (0)1457 899308
 e-mail: info@pressure-tech.com

www.pressure-tech.com



Designed and built in the UK



XHR-301 Series

'Low Flow' Electric and Steam Heated Regulator Piston Sensed for outlet control to 150bar / 2175psi

INSTALLATION DIMENSIONS:

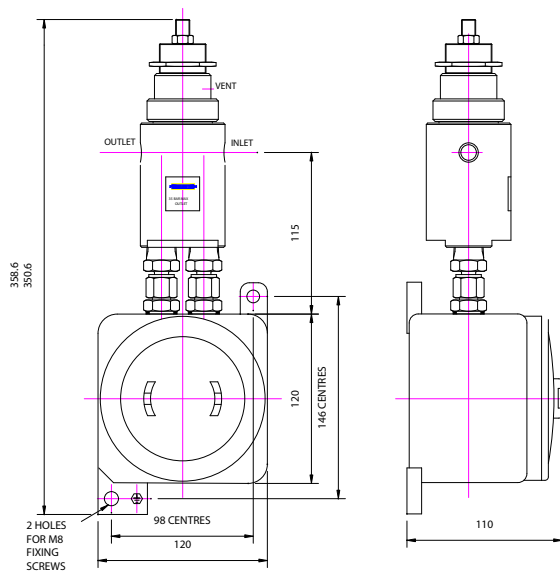

SPECIFICATION :

Max rated inlet pressure ..300bar (4350psi) with PEEK seat
 Outlet ranges up to 150bar (2175psi)
 Design Proof pressure 150% max WP
 LeakageBubble tight at max WP (tested on Nitrogen)
 Weight 4.1kg (2lbs)

ORDERING INFORMATION:

XHR301 - 06 - SS - 50 - K- 1- L - N

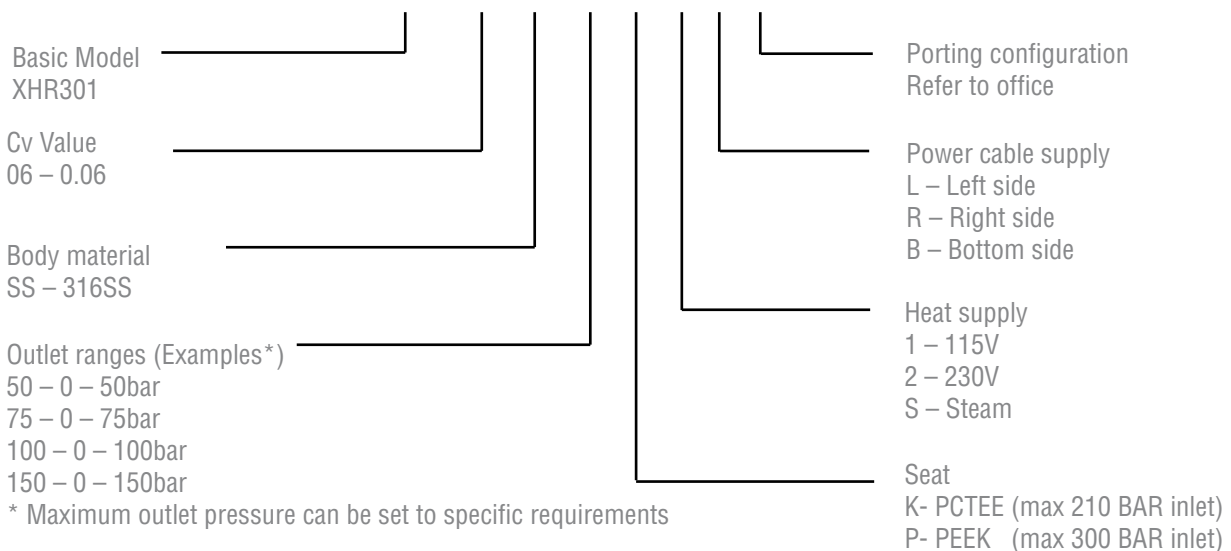

Panel Mounting Ring: PT-C-024

NOTE: Product availability and specifications contained herein are subject to change without notice. Consult local distributor or factory for potential revisions and/or service related issues. // pg 2 of 2