



1 **EC TYPE-EXAMINATION CERTIFICATE**

2 Equipment intended for use in Potentially Explosive Atmospheres Directive 94/9/EC

3 Certificate Number: **Sira 08ATEX1077X** Issue: **0**

4 Equipment: **XHM-300, XHS-300 Series & XHS-301 Series Heated Regulator Assemblies**

5 Applicant: **Pressure Tech Ltd**

6 Address: Unit 3
Rossington Place
Graphite Way
Hadfield
Derbyshire SK13 1QG
UK

7 This equipment and any acceptable variation thereto is specified in the schedule to this certificate and the documents therein referred to.

8 Sira Certification Service, notified body number 0518 in accordance with Article 9 of Directive 94/9/EC of 23 March 1994, certifies that this equipment has been found to comply with the Essential Health and Safety Requirements relating to the design and construction of equipment intended for use in potentially explosive atmospheres given in Annex II to the Directive.

The examination and test results are recorded in the confidential reports listed in Section 14.2.

9 Compliance with the Essential Health and Safety Requirements, with the exception of those listed in the schedule to this certificate, has been assured by compliance with the following documents:

EN 60079-0:2006

EN 60079-1:2007

10 If the sign 'X' is placed after the certificate number, it indicates that the equipment is subject to special conditions for safe use specified in the schedule to this certificate.

11 This EC type-examination certificate relates only to the design and construction of the specified equipment. If applicable, further requirements of this Directive apply to the manufacture and supply of this equipment.

12 The marking of the equipment shall include the following:



II 2 G

Ex d IIC Gb T3 Ta = -40°C to +55°C

C Ellaby
Certification Officer

Project Number 51A16632
C. Index 06

This certificate and its schedules may only be reproduced in its entirety and without change.



SCHEDULE

EC TYPE-EXAMINATION CERTIFICATE

Sira 08ATEX1077X
Issue 0

13 DESCRIPTION OF EQUIPMENT

The XHM-300 Series, as detailed in Figure 1, are electronically heated manifolds intended for altering the temperature of a flowing media. The XHM-300 comprises two main parts:

- i. The heated manifold block, this consists of 2 inlet/outlet ports.
- ii. The electronics that controls the heat input to the regulator - installed inside a Type EAB flameproof enclosure manufactured by Cooper Crouse Hinds.

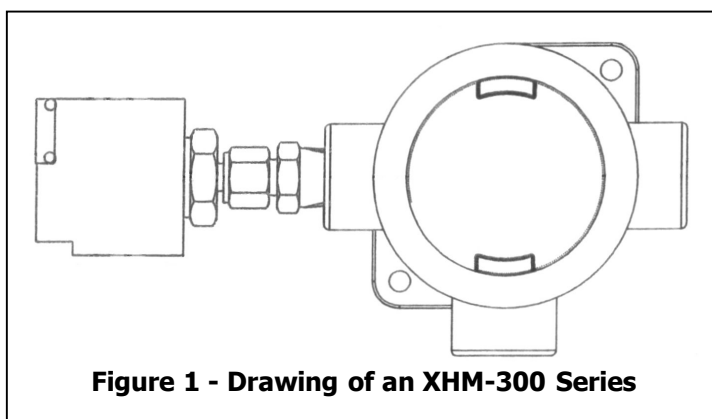

Figure 1 - Drawing of an XHM-300 Series

The manifold is manufactured from 316 stainless steel and protrudes from the electronics housing via a 1/2" NPT threaded cable entry point. The electronics housing is manufactured from aluminium alloy, with mounting lugs to provide a secure means of locating.

The manifold is fitted with a single heater sheath, with a 150 W cartridge heater located within. An adjustable potentiometer on the surface of a potted PCB board located within the electronics housing controls the amount of heat output via a burst-firing controller.

The cartridge is fitted with a 'Type J' sensor, which monitors the temperature to the unit. Should this sensor fail, or the wiring become disconnected, the PCB will not apply power to the heater cartridge.

A thermal fuse with a 187°C ($\pm 2^\circ\text{C}$) limit is placed near the base of the cartridge to protect the regulators from exceeding their T3 temperature rating. The fuse being non-resettable.

The XHS-300 Series, as detailed in Figure 2, are heated single stage diaphragm-sensed pressure regulators. The XHS-300 comprise two main parts:

- i. The mechanical regulator, capable of a maximum 300 bar inlet pressure which may be reduced down to a maximum 35 bar outlet pressure.
- ii. The electronics that control the heat input to the regulator - installed inside a Type EAB flameproof enclosure manufactured by Cooper Crouse Hinds.

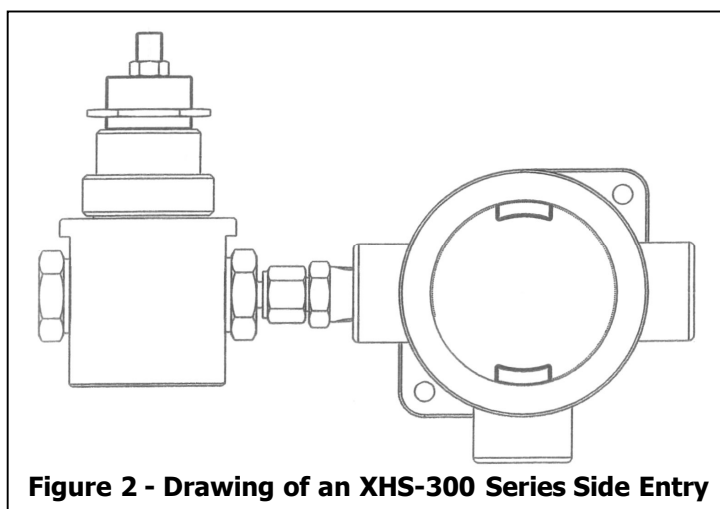

Figure 2 - Drawing of an XHS-300 Series Side Entry

The regulator housing is manufactured from 316 stainless steel. and protrudes from the electronics housing via a 1/2" NPT threaded cable entry point. The electronics housing is manufactured from aluminium alloy, with mounting lugs to provide a secure means of locating.

This certificate and its schedules may only be reproduced in its entirety and without change.



SCHEDULE

EC TYPE-EXAMINATION CERTIFICATE

**Sira 08ATEX1077X
Issue 0**

The regulator is fitted with a single heater sheath, with a 100 W cartridge heater located within. An adjustable potentiometer on the surface of a potted PCB board within the electronics housing controls the amount of heat output via a burst-firing controller. The cartridge is fitted with a 'Type J' sensor, which monitors the temperature to the unit. Should the sensor fail, or the wiring become disconnected, the PCB will not apply power to the heater cartridge.

A thermal fuse with a 89°C (±2°C) limit is placed near the base of the cartridge to protect the regulators from exceeding their T3 temperature rating. The fuse being non-resettable.

The XHS-301 Series, as detailed in Figure 3, are heated single stage piston-sensed pressure regulators. The regulator predominantly consists of two parts:

- i. The mechanical regulator, capable of a maximum 300 bar inlet pressure, which may be reduced down to a maximum 150 bar outlet pressure.
- ii. The electronics that control the heat input to the regulator - installed inside a Type EAB flameproof enclosure manufactured by Cooper Crouse Hinds.

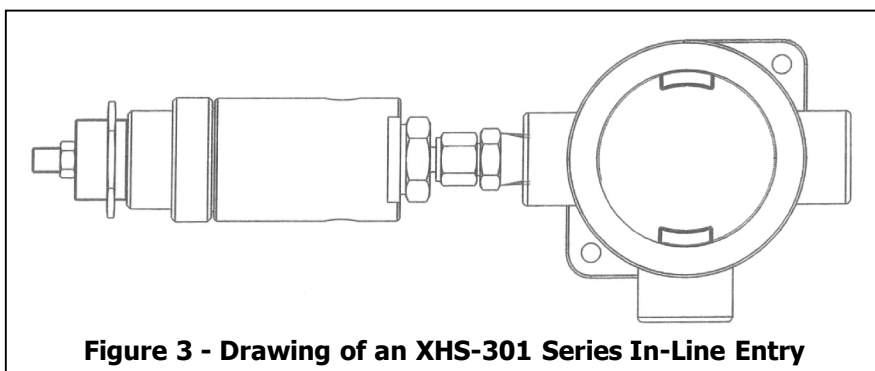

Figure 3 - Drawing of an XHS-301 Series In-Line Entry

The regulator housing is manufactured from 316 stainless steel to ensure protection against the media with which it will be used, and the environment in which it will be placed. The electrical housing is manufactured from aluminium alloy, with mounting lugs to provide a secure means of locating.

The regulator is fitted with a single heater sheath, with a 100 W cartridge heater located within. An adjustable potentiometer on the surface of a potted PCB board within the electronics housing controls the amount of heat output via a burst-firing controller. The cartridge is fitted with a 'type J' sensor, which monitors the temperature to the unit. Should this sensor fail, or the wiring become disconnected, the PCB will not apply power to the heater cartridge.

A thermal fuse with a 89°C limit (±2°C) is placed near the base of the cartridge to protect the regulators from exceeding their T3 temperature rating. This fuse is non-resettable.

XHS-300 outlet pressure ratings:

- 02 – 0 to 2 bar
- 04 – 0 to 4 bar
- 08 – 0 to 8 bar

- 10 – 0 to 10 bar
- 20 – 0 to 20 bar
- 35 – 0 to 35 bar

XHS-301 outlet pressure ratings:

- 50 – 0 to 50 bar
- 75 – 0 to 75 bar
- 100 – 0 to 100 bar
- 150 – 0 to 150 bar

All three products have the following supply parameters:

110 V ac 1 A, 230 V ac 0.5 A

Design Options:

Both the XHS-300 and XHS-301 Series are available in Side Entry or In-Line Entry heating configurations.

This certificate and its schedules may only be reproduced in its entirety and without change.



SCHEDULE

EC TYPE-EXAMINATION CERTIFICATE

Sira 08ATEX1077X
Issue 0

DESCRIPTIVE DOCUMENTS

14.1 Drawings

Refer to Certificate Annexe.

14.2 Associated Sira Reports and Certificate History

Issue	Date	Report No.	Comment
0	19 November 2008	R51A16632A	The release of the prime certificate.

15 SPECIAL CONDITIONS FOR SAFE USE (denoted by X after the certificate number)

- 15.1 The equipment shall not be energised without a regulator or manifold attached.
- 15.2 On non-venting regulators with pressure on the outlet, the hand wheel shall not be turned anti-clockwise, in this case, pressure shall be reduced by venting downstream of the regulator and turning the hand wheel simultaneously anti-clockwise.
- 15.3 An external earth or equipotential bond in accordance with the requirements of EN 60079-0 clause 15 shall be made via one of the mounting holes in the electronics housing base

16 ESSENTIAL HEALTH AND SAFETY REQUIREMENTS OF ANNEX II (EHSRs)

The relevant EHSRs that are not addressed by the standards listed in this certificate have been identified and individually assessed in the reports listed in Section 14.2.

17 CONDITIONS OF CERTIFICATION

- 17.1 The use of this certificate is subject to the Regulations Applicable to Holders of Sira Certificates.
- 17.2 Holders of EC type-examination certificates are required to comply with the production control requirements defined in Article 8 of directive 94/9/EC.
- 17.3 The XHM-300 series shall be fitted with a thermal fuse that has a 187°C limit ($\pm 2^\circ\text{C}$), this shall be installed at the base of the cartridge to protect the regulators from exceeding their T3 temperature rating. The fuse shall be non-resettable.
- 17.4 The XHS-300 and XHS-301 series shall be fitted with a thermal fuse that has a 89°C limit ($\pm 2^\circ\text{C}$), this shall be installed at the base of the cartridge to protect the regulators from exceeding their T3 temperature rating. The fuse shall be non-resettable.

This certificate and its schedules may only be reproduced in its entirety and without change.

Certificate Annexe

Certificate Number: Sira 08ATEX1077X
Equipment: XHM-300, XHS-300 Series & XHS-301 Series
Heated Regulator Assemblies
Applicant: Pressure Tech Ltd



Issue 0

Common Parts

Drawing No:	Rev.	Date	Description
A2-PT-XHS-300-100	G	02 Sep 08	Electrical Heated Regulator XHS300 Electrical Portion
A2-PT-XHS-300-011	B	03 Apr 08	Electrical Heated Junction Box
A2-PT-XHS-300-201	D	03 Apr 08	Circuit Board Assembly
A2-PT-XHS-300-202	D	03 Apr 08	Circuit Board Assembly
A4-PT-XHS-300-010	C	05 Dec 07	Connection Fitting
A4-PT-XHS-300-005	C	31 Mar 08	Heater Sheath
A4-PT-XHS-300-001-002	D	05 Dec 07	Heater Sheath
A4-PT-EHR-300-016-120	B	02 Sep 08	120 V Cartridge Heater 100 Watt
A4-PT-EHR-300-016-230	B	02 Sep 08	230 V Cartridge Heater 100 Watt

XHS-300 (Diaphragm Sensed for 35 bar Max. Outlet)

Drawing No:	Rev.	Date	Description
A4-PT-XHS-300-004	E	03 Apr 08	Heated Regulator Label
A2-PT-XHS-300-INLINE	D	11 Oct 07	Electrical Heated Regulator XHS300 Inline
A2-PT-XHS-300-SE	D	11 Oct 07	Electrical Heated Regulator XHS300 300 Bar
A2-PT-XHS-300-SE-OL	B	15 Oct 07	Electrical heated Regulator XHS300SE Outline
A2-PT-XHS-300-IL-OL	D	11 Oct 07	Single Electric Heated Regulator 300 Bar

XHS-301 (Piston Sensed for 150 bar Max. Outlet)

Drawing No:	Rev.	Date	Description
A4-PT-XHS-301-012	A	03 Apr 08	Heated Regulator Label
A2-PT-XHS-301-INLINE	C	31 Mar 08	Electrical Heated Regulator XHS301 Inline
A2-PT-XHS-301-SE	A	31 Mar 08	Electrical Heated Regulator XHS301 300 Bar

XHM-300 (Heater Manifold)

Drawing No:	Rev.	Date	Description
A4-PT-XHM-300-001	E	03 Apr 08	Heated Manifold Label
A2-PT-XHS-300-HMOL	E	07 Mar 08	Single Electric Heated Manifold 300 Bar
A4-PT-XHM-300-005-115	B	27 Apr 08	Cartridge Heater (For Manifold Block)
A4-PT-XHM-300-005-230	B	27 Apr 08	Cartridge Heater (For Manifold Block)
A2-PT-XHM-300-100	B	03 Apr 08	Electrical Heated Manifold Electrical Portion
A4-PT-XHS-300-008	D	11 Oct 07	Heater Retainer

This certificate and its schedules may only be reproduced in its entirety and without change.